

29176-G01



A Textron Company



OWNER'S MANUAL AND SERVICE GUIDE

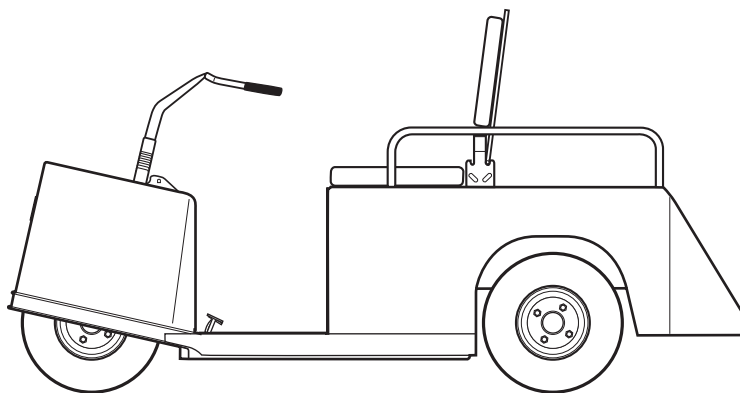

ELECTRIC POWERED THREE WHEEL SERVICE VEHICLE

ISSUED APRIL 2005

SAFETY

Read and understand all labels located on the vehicle. For any questions on any of the information, contact a representative for clarification.

Always replace any damaged or missing labels.

On steep hills it is possible for vehicles to coast at greater than normal speeds encountered on a flat surface. To prevent loss of vehicle control and possible serious injury, speeds should be limited to no more than the maximum speed on level ground. (See vehicle specification.) Limit speed by applying the service brake.

Catastrophic damage to the drive train components due to excessive speed may result from driving the vehicle above specified speed. Damage caused by excessive speed may cause a loss of vehicle control, is costly, is considered abuse and will not be covered under warranty.

If the vehicle is to be used in a commercial environment, signs similar to the ones illustrated should be used to warn of situations that could result in an unsafe condition.

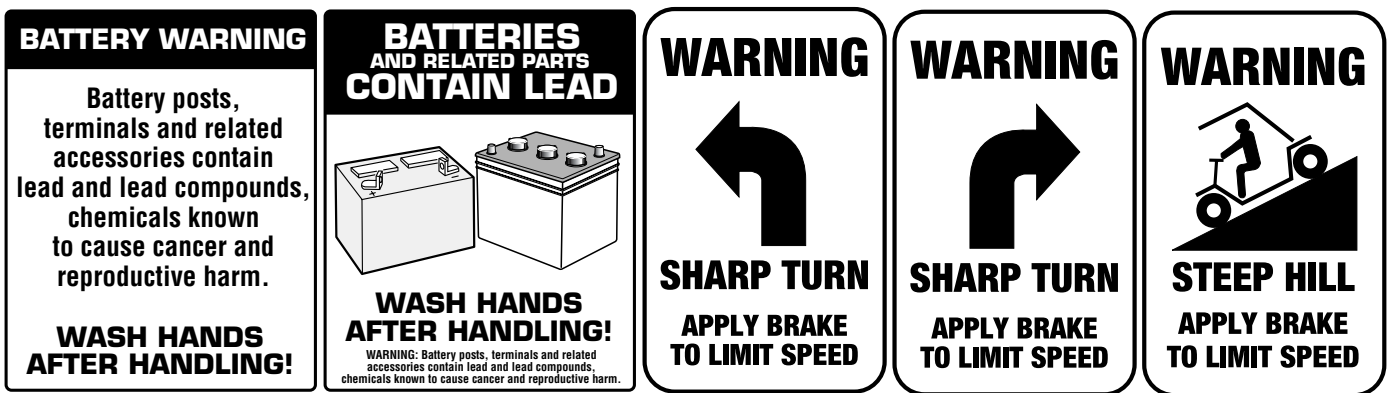

Be sure that this manual remains as part of the permanent service record should the vehicle be resold.

NOTES, CAUTIONS AND WARNINGS

Throughout this guide **NOTE**, **CAUTION** and **WARNING** will be used.

NOTE A **NOTE** indicates a condition that should be observed.

CAUTION A **CAUTION** indicates a condition that may result in damage to the vehicle.

WARNING A **WARNING** indicates a hazardous condition that could result in severe injury or death.

Please observe these **NOTES**, **CAUTIONS** and **WARNINGS**; be aware that servicing a vehicle requires mechanical skill and a regard for conditions that could be hazardous. Improper service or repair may damage the vehicle or render it unsafe.

WARNING Battery posts, terminals and related accessories contain lead and lead compounds. Wash hands after handling.

(NOTES, CAUTIONS AND WARNINGS CONTINUED ON INSIDE OF BACK COVER)

OWNER'S MANUAL AND SERVICE GUIDE

ELECTRIC POWERED THREE WHEEL SERVICE VEHICLE

E-Z-GO INDUSTRIAL 835

Starting Model Year 2004

E-Z-GO Division of TEXTRON, Inc. reserves the right to make design changes without obligation to make these changes on units previously sold and the information contained in this manual is subject to change without notice.

E-Z-GO Division of TEXTRON, Inc. is not liable for errors in this manual or for incidental or consequential damages that result from the use of the material in this manual.

TO CONTACT US

NORTH AMERICA:

TECHNICAL ASSISTANCE & WARRANTY PHONE: 1-800-774-3946, FAX: 1-800-448-8124

SERVICE PARTS PHONE: 1-888-GET-EZGO (1-888-438-3946), FAX: 1-800-752-6175

INTERNATIONAL:

PHONE: 010-1-706-798-4311, FAX: 010-1-706-771-4609

E-Z-GO DIVISION OF TEXTRON, INC., 1451 MARVIN GRIFFIN ROAD, AUGUSTA, GEORGIA USA 30906-3852

NOTES

To obtain a copy of the limited warranty applicable to the vehicle, call or write a local Distributor, an authorized Branch or the Warranty Department with vehicle serial number and manufacturer code.

The use of non Original Equipment Manufacturer (OEM) parts may void the warranty.

Overfilling of batteries may void the warranty.

BATTERY PROLONGED STORAGE

All batteries will self discharge over time. The rate of self discharge varies depending on the ambient temperature and the age and condition of the batteries.

A fully charged battery will not freeze in winter temperatures unless the temperature falls below -75° F (-60° C).

For winter storage, the batteries must be clean, fully charged and disconnected from any source of electrical drain, such as the battery charger. Disconnect the battery charger cable from the vehicle batteries when not charging.

As with all electric vehicles, the batteries must be checked and recharged as required or at a minimum of 30 day intervals.

Refer to the 'Prolonged Storage' section within the BATTERIES AND CHARGING section of this manual.

NOTE

Read and understand the following warnings before attempting to operate the vehicle:

⚠ WARNING ⚠

To prevent personal injury or death, observe the following:

When vehicle is to be left unattended, release pedal completely, move direction selector to neutral, turn key to 'OFF' position and remove key.

Drive vehicle only as fast as terrain and safety considerations allow. Consider the terrain and traffic conditions. Consider environmental factors which effect the terrain and the ability to control the vehicle.

Avoid driving fast down hill. Sudden stops or change of direction may result in a loss of control. Use service brake to control speed when traveling down an incline.

Use extra care and reduced speed when driving on poor surfaces, such as loose dirt, wet grass, gravel, etc.

All travel should be directly up or down hills.

Use extra care when driving the vehicle across an incline.

Stay in designated areas and avoid steep slopes. Use the parking brake whenever the vehicle is parked.

Keep feet, legs, hands and arms inside vehicle at all times.

Avoid extremely rough terrain.

Check area behind the vehicle before operating in reverse.

Make sure the direction selector is in correct position before attempting to start the vehicle.

Slow down before and during turns. All turns should be executed at reduced speed.

Always bring vehicle to a complete stop before shifting the direction selector.

See GENERAL SPECIFICATIONS for standard vehicle load and occupant capacity.

NOTE

Read and understand the following text and warnings before attempting to service vehicle:

In any product, components will eventually fail to perform properly as the result of normal use, age, wear or abuse. It is virtually impossible to anticipate all possible component failures or the manner in which each component may fail.

Be aware that a vehicle requiring repair indicates that the vehicle is no longer functioning as designed and therefore should be considered potentially hazardous. Use extreme care when working on any vehicle. When diagnosing, removing or replacing any components that are not operating correctly, take time to consider the safety of yourself and others around you should the component move unexpectedly.

Some components are heavy, spring loaded, highly corrosive, explosive or may produce high amperage or reach high temperatures. Battery acid and hydrogen gas could result in serious bodily injury to the technician/mechanic and bystanders if not treated with the utmost caution. Be careful not to place hands, face, feet or body in a location that could expose them to injury should an unforeseen situation occur.

⚠ WARNING ⚠

To prevent personal injury or death, observe the following:

Before working on the vehicle, remove all jewelry (rings, watch, necklaces, etc.).

Be sure no loose clothing or hair can contact moving parts.

Use care not to touch hot objects.

Raise entire vehicle and support on jack stands before attempting to run or adjust powertrain.

Wear eye protection when working on or around the vehicle. In particular, use care when working around batteries, using solvents or compressed air.

Hydrogen gas is formed when charging batteries. Do not charge batteries without adequate ventilation.

Do not permit open flame or anyone to smoke in an area that is being used for charging batteries. A concentration of 4% hydrogen gas or more is explosive.

TABLE OF CONTENTS

GENERAL	vii
GENERAL OPERATION	vii
MAINTENANCE	viii
VENTILATION	ix
GENERAL	xi
STANDARDS AND PUBLICATIONS	1
Standards	1
Publications	1
BEFORE INITIAL USE	2
<i>Fig. 1 Initial Service Chart</i>	2
On Board Charger	2
IDENTIFICATION	2
<i>Fig. 2 Model Number, Model Year and Serial Number</i>	2
CONTROLS, METERS AND SWITCHES	2
<i>Fig. 3 Serial Numbers Under Seat</i>	3
<i>Fig. 4 Controls On Dashboard</i>	3
<i>Fig. 5 Controls On Floorboard</i>	3
<i>Fig. 6 Horn Switch</i>	3
Key Switch	3
<i>Fig. 7 Key Switch</i>	4
Direction Selector Switch	4
<i>Fig. 8 Direction Selector Switch</i>	4
Power ON/Battery Condition Meter	4
Headlight (Accessory)	4
Service/Parking Brake Pedal	4
<i>Fig. 9 Speed Control Pedal</i>	4
Speed Control Pedal	5
Horn and Handlebar	5
Handlebar Installation	5
Seat Switch	5
<i>Fig. 10 Seat Switch</i>	5
Hour Meter (Accessory)	5
ADDITIONAL FEATURES	5
Battery Charger	5
Fold Down Backrest	6
<i>Fig. 11 Battery Charger</i>	6
<i>Fig. 12 Fold Down Backrest</i>	6
Programmable Speed Controller	6
EE UNITS	6
BEFORE ENTERING VEHICLE	6
OPERATING THE VEHICLE	6
STARTING THE VEHICLE	7
COASTING	7
OPERATION	7
DRIVING THE VEHICLE	8
SERVICING THE ELECTRIC VEHICLE	9
TOWING	9

TABLE OF CONTENTS

LIFTING THE VEHICLE	9
SAFETY COMPONENTS	10
Seat Switch	10
Thermal Circuit Breaker	10
<i>Fig. 13 Lifting the Vehicle</i>	10
Parking The Vehicle	10
<i>Fig. 14 Parking The Vehicle</i>	10
ROUTINE MAINTENANCE	10
REAR AXLE	11
Checking the Lubricant Level	11
<i>Fig. 15 Lubrication Points</i>	11
<i>Fig. 16 Rear Axle Lubricant Check and Fill</i>	11
BRAKES	11
Test Method	11
<i>Fig. 17 Periodic Brake Performance Test</i>	12
TIRES	12
Tire Repair	13
Wheel Installation	13
<i>Fig. 18 Wheel Installation</i>	13
<i>Fig. 19 Wheel Installation</i>	13
LIGHT BULB REPLACEMENT	14
CARE AND CLEANING OF THE VEHICLE	14
TRAILERING	14
HARDWARE	15
<i>Fig. 20 Bolt Grades</i>	15
TORQUE SPECIFICATIONS	15
<i>Fig. 21 Torque Specifications</i>	15
PERIODIC SERVICE SCHEDULE	16
<i>Fig. 22 Periodic Service Schedule</i>	16
BATTERIES AND CHARGING	18
Safety	18
BATTERY	18
BATTERY MAINTENANCE	18
At Each Charging Cycle	19
Monthly	19
Electrolyte Level and Water	19
<i>Fig. 23 Correct Electrolyte Level</i>	19
<i>Fig. 24 Water Purity Table</i>	19
<i>Fig. 25 Automatic Watering Gun</i>	19
Cleaning Batteries	19
<i>Fig. 26 Preparing Acid Neutralizing Solution</i>	19
Battery Replacement	19
<i>Fig. 27 Battery Connections</i>	20
Prolonged Storage	20
<i>Fig. 28 Freezing Point of Electrolyte</i>	20
Battery Charging	21
AC Voltage	21
TROUBLESHOOTING	22
Hydrometer	22
Using A Hydrometer	23

TABLE OF CONTENTS

<i>Fig. 29 Hydrometer</i>	23
<i>Fig. 30 Hydrometer Temperature Correction</i>	23
<i>Fig. 31 Factory Settings</i>	30
<i>Fig. 32 Wiring Diagram</i>	32
<i>Fig. 32 Wiring Diagram</i>	33
GENERAL SPECIFICATIONS	29
ELECTRIC POWERED THREE WHEEL SERVICE VEHICLE	30
<i>Fig. 33 Vehicle Dimensions and Incline Specifications</i>	31
<i>Fig. 34 Vehicle Turning Clearance Diameter and Intersecting Aisle Clearance</i>	32

SAFETY INFORMATION

This manual has been designed to assist the owner-operator in maintaining the vehicle in accordance with procedures developed by the manufacturer. Adherence to these procedures and troubleshooting tips will ensure the best possible service from the product. To reduce the chance of personal injury and/or property damage, the following instructions must be carefully observed:

CAUTION

Certain replacement parts can be used independently and/or in combination with other accessories to modify an E-Z-GO-manufactured vehicle to permit the vehicle to operate at or in excess of 20mph. When an E-Z-GO-manufactured vehicle is modified in any way by the Distributor, Dealer or customer to operate at or in excess of 20mph, UNDER FEDERAL LAW the modified product will be a Low Speed Vehicle (LSV) subject to the strictures and requirements of Federal Motor Vehicle Safety Standard 571.500. In these instances, pursuant to Federal law the Distributor or Dealer MUST equip the product with headlights, rear lights, turn signals, seat belts, top, horn and all other modifications for LSV's mandated in FMVSS 571.500, and affix a Vehicle Identification Number to the product in accordance with the requirements of FMVSS 571.565. Pursuant to FMVSS 571.500, and in accordance with the State laws applicable in the places of sale and use of the product, the Distributor, Dealer or customer modifying the vehicle also will be the Final Vehicle Manufacturer for the LSV, and required to title or register the vehicle as mandated by State law.

E-Z-GO will NOT approve Distributor, Dealer or customer modifications converting E-Z-GO products into LSV's.

The Company, in addition, recommends that all E-Z-GO products sold as personal transportation vehicles BE OPERATED ONLY BY PERSONS WITH VALID DRIVERS LICENSES, AND IN ACCORDANCE WITH APPLICABLE STATE REQUIREMENTS. This restriction is important to the SAFE USE AND OPERATION of the product. On behalf of E-Z-GO, I am directing that E-Z-GO Branch personnel, Distributors and Dealers advise all customers to adhere to this SAFETY RESTRICTION, in connection with the use of all products, new and used, the Distributor or Dealer has reason to believe may be operated in personal transportation applications.

Information on FMVSS 571.500 can be obtained at Title 49 of the Code of Federal Regulations, section 571.500, or through the Internet at the website for the U.S. Department of Transportation - at Dockets and Regulation, then to Title 49 of the Code of Federal Regulations (Transportation).

GENERAL

Many vehicles are used for a variety of tasks beyond the original intended use of the vehicle; therefore it is impossible to anticipate and warn against every possible combination of circumstances that may occur. No warnings can take the place of good common sense and prudent driving practices.

Good common sense and prudent driving practices do more to prevent accidents and injury than all of the warnings and instructions combined. The manufacturer strongly suggests that the owner-operator read this entire manual paying particular attention to the CAUTIONS and WARNINGS contained therein. It is further recommended that employees and other operators be encouraged to do the same.

If you have any questions, contact your closest representative or write to the address on the back cover of this publication, Attention: Product Service Department.

E-Z-GO Division of TEXTRON Inc., reserves the right to make design changes without obligation to make these changes on units previously sold and the information contained in this manual is subject to change without notice.

E-Z-GO Division of TEXTRON Inc., is not liable for errors in this manual or for incidental or consequential damages that result from the use of the material in this manual.

SAFETY INFORMATION

This vehicle conforms to the current applicable standard for safety and performance requirements.

These vehicles do not conform to Federal Motor Vehicle Safety Standards and are not equipped for operation on public streets.

With electric powered vehicles, be sure that all electrical accessories are grounded directly to the battery (-) post. **Never use the chassis or body as a ground connection.**

Refer to GENERAL SPECIFICATIONS for vehicle seating capacity.

Never modify the vehicle in any way that will alter the weight distribution of the vehicle, decrease its stability or increase the speed beyond the factory specification. Such modifications can cause serious personal injury or death. Modifications that increase the speed and/or weight of the vehicle will extend the stopping distance and may reduce the stability of the vehicle. Do not make any such modifications or changes. The manufacturer prohibits and disclaims responsibility for any such modifications or any other alteration which would adversely affect the safety of the vehicle.

GENERAL OPERATION

Always use the vehicle in a responsible manner and maintain the vehicle in safe operating condition.

Always read and observe all warnings and operation instruction labels affixed to the vehicle.

Always follow all safety rules established in the area where the vehicle is being operated.

Always reduce speed to compensate for poor terrain or conditions.

Always apply service brake to control speed on steep grades.

Always maintain adequate distance between vehicles.

Always reduce speed in wet areas.

Always use extreme caution when approaching sharp or blind turns.

Always use extreme caution when driving over loose terrain.

Always use extreme caution in areas where pedestrians are present.

MAINTENANCE

Always maintain your vehicle in accordance with the manufacturer's periodic service schedule.

Always ensure that mechanics performing repairs are trained and qualified to do so.

Always follow the manufacturer's directions if you do any maintenance on your vehicle. Be sure to disable the vehicle before performing any maintenance. Disabling includes removing the key from the key switch and removal of a battery wire.

Always insulate any tools used within the battery area in order to prevent sparks or battery explosion caused by shorting the battery terminals or associated wiring. Remove the batteries or cover exposed terminals with an insulating material.

SAFETY INFORMATION

Always check the polarity of each battery terminal and be sure to rewire the batteries correctly.

Always use specified replacement parts. Never use replacement parts of lesser quality.

Always use recommended tools.

Always determine that tools and procedures not specifically recommended by the manufacturer will not compromise the safety of personnel nor jeopardize the safe operation of the vehicle.

Always support the vehicle using wheel chocks and safety stands. Never get under a vehicle that is supported by a jack. Lift the vehicle in accordance with the manufacturer's instructions.

Never attempt to maintain a vehicle in an area where exposed flame is present or persons are smoking.

Always be aware that a vehicle that is not performing as designed is a potential hazard and must not be operated.

The manufacturer cannot anticipate all situations, therefore people attempting to maintain or repair the vehicle must have the skill and experience to recognize and protect themselves from potential situations that could result in severe personal injury or death and damage to the vehicle. Use extreme caution and, if unsure as to the potential for injury, refer the repair or maintenance to a qualified mechanic.

Always test drive the vehicle after any repairs or maintenance. All tests must be conducted in a safe area that is free of both vehicular and pedestrian traffic.

Always replace damaged or missing warning, caution or information labels.

Always keep complete records of the maintenance history of the vehicle.

VENTILATION

Hydrogen gas is generated in the charging cycle of batteries and is explosive in concentrations as low as 4%. Because hydrogen gas is lighter than air, it will collect in the ceiling of buildings necessitating proper ventilation. Five air exchanges per hour is considered the minimum requirement.

Never charge a vehicle in an area that is subject to flame or spark. Pay particular attention to natural gas or propane gas water heaters and furnaces.

Always use a dedicated circuit for each battery charger. Do not permit other appliances to be plugged into the receptacle when the charger is in operation.

Chargers must be installed and operated in accordance with charger manufacturers recommendations or applicable electrical code (whichever is more restrictive).

SAFETY INFORMATION

Read all of manual to become thoroughly familiar with this vehicle. Pay particular attention to all Notes, Cautions and Warnings

GENERAL

The following text is provided as recommended by part II of ASME/ANSI B56.8-1988. The manufacturer strongly endorses the contents of this specification.

PART II FOR THE USER

4 GENERAL SAFETY PRACTICES

4.1 Introduction

4.1.1 Like other machines, carriers can cause injury if improperly used or maintained. Part II contains broad safety practices applicable to carrier operations. Before operation, the user shall establish such additional specific safety practices as may reasonably be required for safe operation.

4.2 Stability

4.2.1 Experience has shown that this vehicle, which complies with this standard, is stable when properly operated and when operated in accordance with specific safety rules and practices established to meet actual operating terrain and conditions. However, improper operation, faulty maintenance, or poor housekeeping may contribute to a condition of instability and defeat the purpose of the standard. Some of the conditions which may affect stability are failure of the user to follow safety practices; also, ground and floor conditions, grade, speed, loading, the operation of the carrier with improper loads, battery weight, dynamic and static forces, and the judgement exercised by the carrier operator.

(a) The user shall train carrier operators to adhere strictly to the operating instructions stated in this Standard.

(b) The user shall survey specific operating conditions and environment, and establish and train carrier operators to comply with additional, specific safety practices.

4.3 Nameplates, Markings, Capacity, and Modifications

4.3.1 The user shall maintain in a legible condition all nameplates, warnings, and instructions which are supplied by the manufacturer.

4.3.2 The user shall not perform any modification or addition which affects capacity or safe operation, or make any change not in accordance with the owner's

manual without the manufacturer's prior written authorization. Where authorized modifications have been made, the user shall ensure that capacity, operation, warning, and maintenance instruction plates, tags, or decals are changed accordingly.

4.3.3 As required under paras. 4.3.1 or 4.3.2, the manufacturer shall be contacted to secure new nameplates, warnings, or instructions which shall then be affixed in their proper place on the carrier.

4.4 Fuel Handling and Storage

4.4.1 The user shall supervise the storage and handling of liquid fuels (when used) to be certain that it is in accordance with appropriate paragraphs of ANSI/NFPA 505 and ANSI/NFPA 30.

4.4.2 Storage and handling of liquefied petroleum gas fuels shall be in accordance with appropriate paragraphs of ANSI/NFPA 505 and ANSI/NFPA 58. If such storage or handling is not in compliance with these standards, the user shall prevent the carrier from being used until such storage and handling is in compliance with these standards.

4.5 Changing and Charging Storage Batteries for Electric Personnel and Burden Carriers

4.5.1 The user shall require battery changing and charging facilities and procedures to be in accordance with appropriate paragraphs of ANSI/NFPA 505.

4.5.2 The user shall periodically inspect facilities and review procedures to be certain that appropriate paragraphs of ANSI/NFPA 505, are strictly complied with, and shall familiarize carrier operators with it.

4.6 Hazardous Locations

4.6.1 The user shall determine the hazard classification of the particular atmosphere or location in which the carrier is to be used in accordance with ANSI/NFPA 505.

4.6.2 The user shall permit in hazardous areas only those carriers approved and of the type required by ANSI/NFPA 505.

4.7 Lighting for Operating Areas

4.7.1 The user, in accordance with his responsibility to survey the environment and operating conditions, shall determine if the carrier requires lights and, if so, shall equip the carrier with appropriate lights in accordance with the manufacturer's recommendations.

SAFETY INFORMATION

Read all of manual to become thoroughly familiar with this vehicle. Pay particular attention to all Notes, Cautions and Warnings

4.8 Control of Noxious Gases and Fumes

4.8.1 When equipment powered by internal combustion engines is used in enclosed areas, the atmosphere shall be maintained within limits specified in the American Conference of Governmental Industrial Hygienists publication, "Threshold Limit Values for Chemical Substances and Physical Agents in the Workroom Environment". This shall be accomplished by ventilation provided by the user, and/or the installation, use, and proper maintenance of emission control equipment recommended or provided by the manufacturer of the equipment.

4.9 Warning Device(s)

4.9.1 The user shall make periodic inspections of the carrier to be certain that the sound-producing and/or visual device(s) are maintained in good operating condition.

4.9.2 The user shall determine if operating conditions require the carrier to be equipped with additional sound-producing and/or visual devices and be responsible for providing and maintaining such devices, in accordance with the manufacturer's recommendations.

5 OPERATING SAFETY RULES AND PRACTICES

5.1 Personnel and Burden Carrier Operator Qualifications

5.1.1 Only persons who are trained in the proper operation of the carrier shall be authorized to operate the carrier. Operators shall be qualified as to visual, auditory, physical, and mental ability to safely operate the equipment according to Section 5 and all other applicable parts of this Standard.

5.2 Personnel and Burden Carrier Operator's Training

5.2.1 The user shall conduct an operator's training program.

5.2.2 Successful completion of the operator's training program shall be required by the user before operation of the carrier. The program shall be presented in its entirety to all new operators and not condensed for those claiming previous experience.

5.2.3 The user should include in the operators' training program the following:

- (a) instructional material provided by the manufac-

turer;

- (b) emphasis on safety of passengers, material loads, carrier operator, and other employees;

- (c) general safety rules contained within this Standard and the additional specific rules determined by the user in accordance with this Standard, and why they were formulated;

- (d) introduction of equipment, control locations and functions, and explanation of how they work when used properly and when used improperly, and surface conditions, grade, and other conditions of the environment in which the carrier is to be operated;

- (e) operational performance tests and evaluations during, and at completion of, the program.

5.3 Personnel and Burden Carrier Operator Responsibility

5.3.1 Operators shall abide by the following safety rules and practices in paras. 5.4, 5.5, 5.6, and 5.7.

5.4 General

5.4.1 Safeguard the pedestrians at all times. Do not drive carrier in a manner that would endanger anyone.

5.4.2 Riding on the carrier by persons other than the operator is authorized only on personnel seat(s) provided by the manufacturer. All parts of the body shall remain within the plan view outline of the carrier.

5.4.3 When a carrier is to be left unattended, stop carrier, apply the parking brake, stop the engine or turn off power, turn off the control or ignition circuit, and remove the key if provided. Block the wheels if machine is on an incline.

5.4.4 A carrier is considered unattended when the operator is 25 ft. (7.6 m) or more from the carrier which remains in his view, or whenever the operator leaves the carrier and it is not within his view. When the operator is dismounted and within 25 ft. (7.6 m) of the carrier still in his view, he still must have controls neutralized, and the parking brake(s) set to prevent movement.

5.4.5 Maintain a safe distance from the edge of ramps and platforms.

5.4.6 Use only approved carriers in hazardous locations, as defined in the appropriate safety standards.

5.4.7 Report all accidents involving personnel, building structures, and equipment.

5.4.8 Operators shall not add to, or modify, the carrier.

SAFETY INFORMATION

Read all of manual to become thoroughly familiar with this vehicle. Pay particular attention to all Notes, Cautions and Warnings

5.4.9 Carriers shall not be parked or left unattended such that they block or obstruct fire aisles, access to stairways, or fire equipment.

5.5 Traveling

5.5.1 Observe all traffic regulations, including authorized speed limits. Under normal traffic conditions keep to the right. Maintain a safe distance, based on speed of travel, from a carrier or vehicle ahead; and keep the carrier under control at all times.

5.5.2 Yield the right of way to pedestrians, ambulances, fire trucks, or other carriers or vehicles in emergency situations.

5.5.3 Do not pass another carrier or vehicle traveling in the same direction at intersections, blind spots, or at other dangerous locations.

5.5.4 Keep a clear view of the path of travel, observe other traffic and personnel, and maintain a safe clearance.

5.5.5 Slow down or stop, as conditions dictate, and activate the sound-producing warning device at cross aisles and when visibility is obstructed at other locations.

5.5.6 Ascend or descend grades slowly.

5.5.7 Avoid turning, if possible, and use extreme caution on grades, ramps, or inclines; normally travel straight up and down.

5.5.8 Under all travel conditions the carrier shall be operated at a speed that will permit it to be brought to a stop in a safe manner.

5.5.9 Make starts, stops, turns, or direction reversals in a smooth manner so as not to shift the load, endanger passengers, or overturn the carrier.

5.5.10 Do not indulge in dangerous activities, such as stunt driving or horseplay.

5.5.11 Slow down when approaching, or on, wet or slippery surfaces.

5.5.12 Do not drive carrier onto any elevator unless specifically authorized to do so. Approach elevators slowly, and then enter squarely after the elevator car is properly leveled. Once on the elevator, neutralize the controls, shut off power, and set parking brakes. It is advisable that all other personnel leave the elevator before a carrier is allowed to enter or exit.

5.5.13 Avoid running over loose objects, potholes, and bumps.

5.5.14 To negotiate turns, reduce speed to improve stability, then turn hand steering wheel or tiller in a

smooth, sweeping motion.

5.6 Loading

5.6.1 Handle only stable and safely arranged loads. When handling off-center loads which cannot be centered, operate with extra caution.

5.6.2 Handle only loads within the capacity of the carrier as specified on the nameplate.

5.6.3 Handle loads exceeding the dimensions used to establish carrier capacity with extra caution. Stability and maneuverability may be adversely affected.

5.7 Operator Care of Personnel and Burden Carriers

5.7.1 At the beginning of each shift during which the carrier will be used, the operator shall check the carrier condition and inspect the tires, warning devices, lights, battery(s), speed and directional controllers, brakes, and steering mechanism. If the carrier is found to be in need of repair, or in any way unsafe, the matter shall be reported immediately to the designated authority and the carrier shall not be operated until it has been restored to safe operating condition.

5.7.2 If during operation the carrier becomes unsafe in any way, the matter shall be reported immediately to the designated authority, and the carrier shall not be operated until it has been restored to safe operating condition.

5.7.3 Do not make repairs or adjustments unless specifically authorized to do so.

5.7.4 The engine shall be stopped and the operator shall leave the carrier while refueling.

5.7.5 Spillage of oil or fuel shall be carefully and completely absorbed or evaporated and fuel tank cap replaced before starting engine.

5.7.6 Do not operate a carrier with a leak in the fuel system or battery(s).

5.7.7 Do not use open flames for checking electrolyte level in storage battery(s) or liquid level in fuel tanks.

6 MAINTENANCE PRACTICES

6.1 Introduction

6.1.1 Carriers may become hazardous if maintenance is neglected. Therefore, maintenance facilities, trained personnel, and procedures shall be provided. Such facilities may be on or off the premises.

SAFETY INFORMATION

Read all of manual to become thoroughly familiar with this vehicle. Pay particular attention to all Notes, Cautions and Warnings

6.2 Maintenance Procedures

6.2.1 Maintenance and inspection of all carriers shall be performed in conformance with the manufacturer's recommendations and the following practices.

(a) A scheduled preventive maintenance, lubrication, and inspection system shall be followed.

(b) Only qualified and authorized personnel shall be permitted to maintain, repair, adjust, and inspect carriers.

(c) Before undertaking maintenance or repair, follow the manufacturer's recommendations for immobilizing the carrier.

(d) Block chassis before working underneath it.

(e) Before disconnecting any part of the engine fuel system of a gasoline or diesel powered carrier with gravity feed fuel systems, be sure shutoff valve is closed, and run engine until fuel system is depleted and engine stops running.

(f) Before disconnecting any part of the engine fuel system of LP gas powered carriers, close the LP gas cylinder valve and run the engine until fuel in the system is depleted and the engine stops running.

(g) Operation to check performance of the carrier shall be conducted in an authorized area where safe clearance exists.

(h) Before commencing operation of the carrier, follow the manufacturer's instructions and recommended procedures.

(i) Avoid fire hazards and have fire protection equipment present in the work area. Do not use an open flame to check level or leakage of fuel, battery electrolyte, or coolant. Do not use open pans of fuel or flammable cleaning fluids for cleaning parts.

(j) Properly ventilate the work area.

(k) Handle LP gas cylinders with care. Physical damage, such as dents, scrapes, or gouges, may dangerously weaken the tank and make it unsafe for use.

(l) Brakes, steering mechanisms, speed and directional control mechanisms, warning devices, lights, governors, guards, and safety devices shall be inspected regularly and maintained in a safe operating condition.

(m) Special carriers or devices designed and approved for hazardous area operation shall be inspected to ensure that maintenance preserves the original approved safe operating features.

(n) Fuel systems shall be checked for leaks and condition of parts. If a leak is found, action shall be taken to

prevent the use of the carrier until the leak has been eliminated.

(o) The carrier manufacturer's capacity, operation, and maintenance instruction plates, tags, or decals shall be maintained in legible condition.

(p) Batteries, motors, speed and directional controllers, limit switches, protective devices, electrical conductors, and connections shall be inspected and maintained in conformance with manufacturers recommended procedures.

(q) Carriers shall be kept in a clean condition to minimize fire hazards and facilitate detection of loose or defective parts.

(r) Modifications and additions which affect capacity and safe machine operation shall not be performed by the customer or user without manufacturer's prior written authorization; where authorized modifications have been made, the user shall ensure that capacity, operation, warning, and maintenance instruction plates, tags, or decals are changed accordingly.

(s) Care shall be taken to ensure that all replacement parts are interchangeable with the original parts and of a quality at least equal to that provided in the original equipment.

ELECTRIC THREE WHEEL SERVICE VEHICLE

Read all of manual to become thoroughly familiar with this vehicle. Pay particular attention to all Notes, Cautions and Warnings

STANDARDS AND PUBLICATIONS

This unit is not a motor vehicle within the definition of the National Traffic Motor Vehicle Safety Act. It is not designed or manufactured for use on roads, streets, or highways, and is not appropriate for such use. This unit is not meant to be licensed as a motor vehicle.

The Electric 3 wheel service vehicle is available as Type "E" and Type "EE" Units. Type "E" Units are electrically powered units having minimum acceptable safeguards against inherent fire hazards. Type "EE" Units have additional safeguards against such hazards.

Users, operators and service persons should be familiar with the following standards and publications:

Standards

(The material may be obtained from the address shown).

- Factory Mutual Approval Standard:
Class # 7820; Electric Battery Powered Trucks,
Types E and EE.
ADDRESS:
Factory Mutual Research Corp.
1151 Boston--Providence Highway
Norwood, Massachusetts 02062 USA
- National Fire Protection Association:
ANSI/NFPA #505; Powered Industrial Trucks.
ADDRESS:
National Fire Protection Association
Batterymarch Park
Quincy, Massachusetts 02269 USA
- ANSI/ASME B56.8
Personnel and Burden Carriers
ADDRESS:
American National Standards Institute, Inc.
1430 Broadway
New York, New York 10018 USA

- ANSI/UL 583; Electric Battery Powered Industrial Trucks

ADDRESS:

American National Standards Institute, Inc.
1430 Broadway
New York, New York 10018 USA

OR

Underwriters Laboratories Inc.
333 Pfingsten Road
Northbrook, Illinois 60062 USA

This Electric Vehicle complies with ANSI B56.8 as it applies to OSHA for Powered Industrial Trucks under the Type E and EE classifications. This vehicle has been approved by Factory Mutual Research Corporation. To meet the manufacturer portions of the OSHA requirements (as stated in section 1910.178, Paragraph a3) Powered Industrial Trucks must bear the approval mark of either UL (Underwriters Laboratory) or FM (Factory Mutual) or other nationally recognized testing laboratories.

Publications

Additional operator's manuals and parts manuals are available for a minimum charge.

Parts Manual 29177-G01

Repair Manual 29178-G01

Thank you for this purchase. The vehicle is equipped with an electronic speed control unit that is the most advanced in the industry. Before driving the vehicle, we ask you to spend some time reading this Owner's Manual and Service Guide. This guide contains information that will assist you in maintaining your highly reliable vehicle. Some illustrations may show items that are optional for your vehicle.

Most of the service procedures in this guide can be accomplished by an individual using common automotive hand tools. Refer to an authorized service representative for information on servicing the vehicle in accordance with the Periodic Service Schedule.

To facilitate maintenance, a Service Parts Manual and a Technician's Repair and Service Manual is available from a local Distributor, an authorized Branch or the Service Parts Department. When ordering parts or requesting information for your vehicle, provide vehicle model, serial number and manufacture code.

ELECTRIC THREE WHEEL SERVICE VEHICLE

Read all of manual to become thoroughly familiar with this vehicle. Pay particular attention to all Notes, Cautions and Warnings

BEFORE INITIAL USE

Read, understand and follow safety label on the instrument panel. The vehicle has been designed to operate in a warehouse or factory environment with semi-smooth floors, road and ramps.

Be sure you understand the vehicle, its equipment and how to use it safely. Although the vehicle has been designed to provide safe and reliable operation, maintaining good performance depends to a large extent on the operator.

Vehicle batteries must be fully charged before initial use.



Hydrogen gas is generated as a natural part of the lead acid battery charging process. A 4% concentration of hydrogen gas is explosive and could cause severe injury or death. Charging must take place in an area that is adequately ventilated (minimum of 5 air exchanges per hour).

To reduce the chance of battery explosion that could result in severe injury or death, never smoke around or charge batteries in an area that has open flame or electrical equipment that could cause an electrical arc.

Hydrogen gas is generated in the charging cycle of batteries and is explosive in concentrations as low as 4%. Because hydrogen gas is lighter than air, it will collect in the ceiling of buildings necessitating proper ventilation. Five air exchanges per hour is considered the minimum requirement.

Never charge a vehicle in an area that is subject to flame or spark. Pay particular attention to natural gas or propane gas water heaters and furnaces.

Before a new vehicle is put into operation, it is recommended that the items listed in the INITIAL SERVICE CHART be performed (Ref Fig. 1 on page 2).

ITEM	SERVICE OPERATION
Batteries	Charge batteries
Seats	Remove protective plastic covering
Brakes	Check operation and adjust if necessary
Tires	Check air pressure (see SPECIFICATIONS)

Fig. 1 Initial Service Chart

On Board Charger

The on board charger is wired directly to the batteries, only requiring it be plugged into a dedicated 15 amp AC outlet to be operational. When charge cycle is complete, replace cord in appropriate area under cargo deck.

IDENTIFICATION

The product model number, model year and serial number must appear on all correspondence concerning this unit. These identification numbers appear on the decal attached to the left side of the kick panel.(Ref Fig. 2 on page 2).

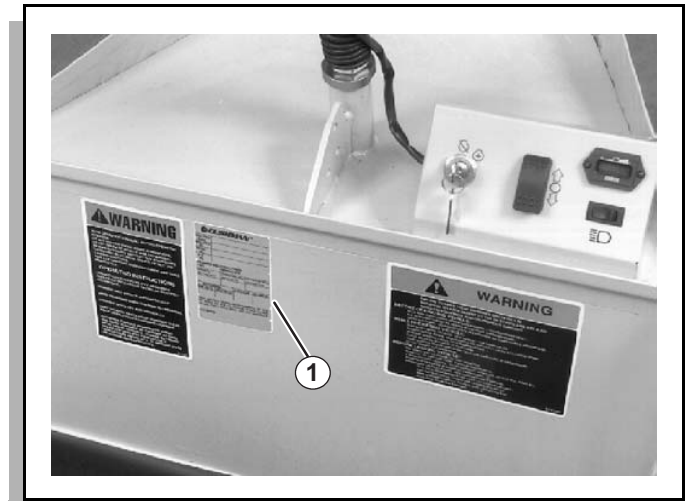

Fig. 2 Model Number, Model Year and Serial Number

1. Model Number, Model Year and Serial Number.

The vehicle serial number is located under the seat. (Ref Fig. 3 on page 3)

CONTROLS, METERS AND SWITCHES

The controls, meters and switches consist of:

- key switch
- direction selector switch
- power on/battery condition meter
- headlight (accessory; standard on EE models; not shown)
- service/parking brake pedal
- speed control pedal
- horn
- seat switch
- hour meter (accessory; not shown. Located under rear deck.)

ELECTRIC THREE WHEEL SERVICE VEHICLE

Read all of manual to become thoroughly familiar with this vehicle. Pay particular attention to all Notes, Cautions and Warnings

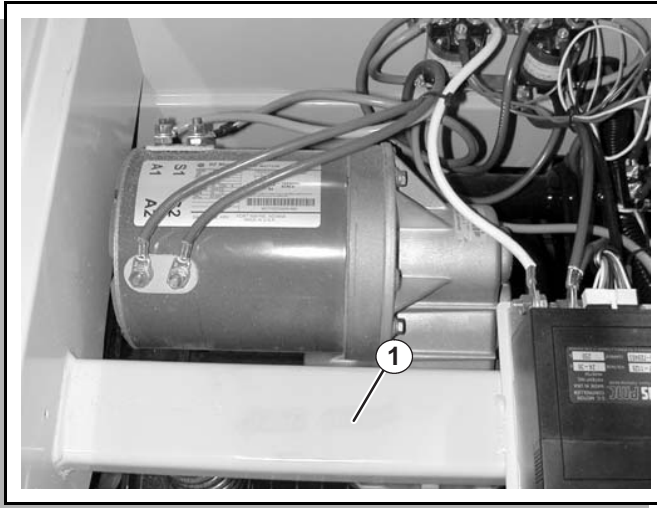

Fig. 3 Serial Numbers Under Seat

1. Serial Numbers Under Seat.

(Ref. Fig. 4 on page 3) and (Ref. Fig. 5 on page 3) show the controls on the dash and the floorboard.

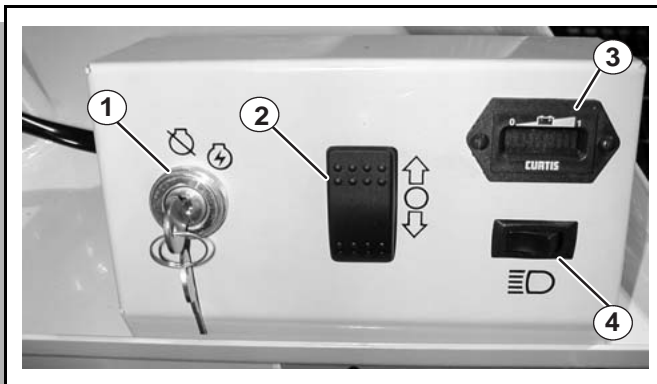

Fig. 4 Controls On Dashboard

1. Key Switch
2. Direction Selector Switch
3. Power On/Battery Condition Meter
4. Headlight Switch

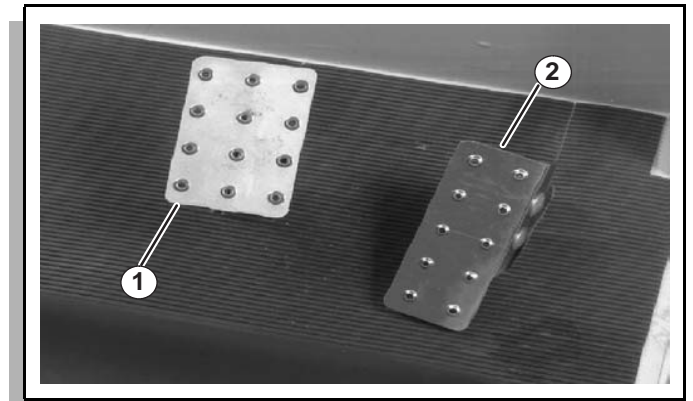

Fig. 5 Controls On Floorboard

1. Service/Parking Brake Pedal
2. Speed Control Pedal

(Ref Fig. 6 on page 3) shows the horn button and handlebar.

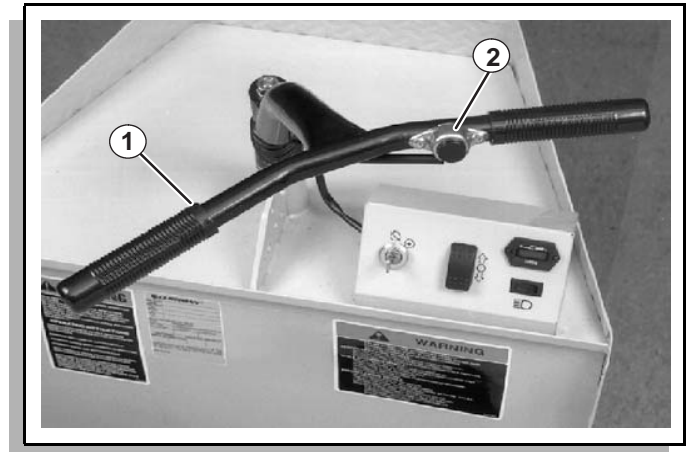

Fig. 6 Horn Switch

1. Handlebar
2. Horn

Key Switch

The key switch, located in the vehicle dash, supplies or interrupts power to the vehicle electrical system.

ELECTRIC THREE WHEEL SERVICE VEHICLE

Read all of manual to become thoroughly familiar with this vehicle. Pay particular attention to all Notes, Cautions and Warnings

ON POSITION: Supplies power

OFF POSITION: Interrupts power (Ref Fig. 7 on page 4)

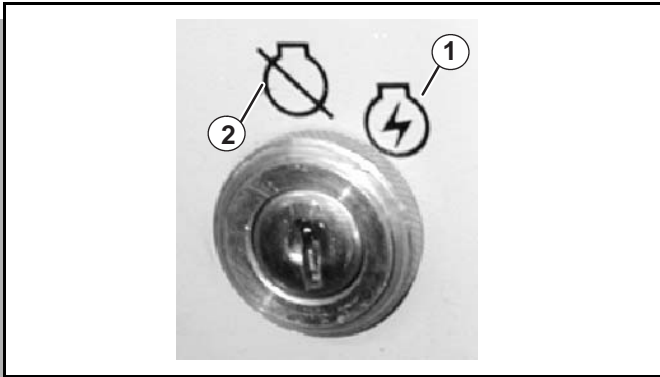

Fig. 7 Key Switch

1. On Position
2. Off Position



WARNING To prevent unexpected vehicle movement or unauthorized use, always turn the key switch to the OFF position and remove the key when the vehicle is not in use.

Direction Selector Switch

The direction selector switch, located on the dash panel, controls the direction of vehicle movement. The panel is marked with FORWARD, NEUTRAL and REVERSE positions. Push to the NEUTRAL position when leaving the vehicle seat.

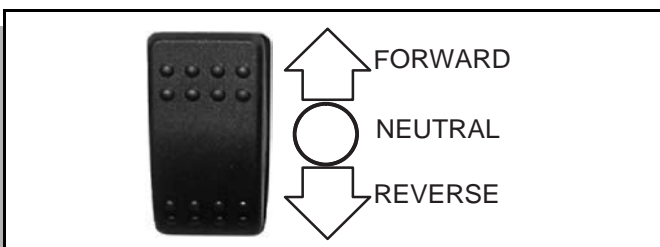

Fig. 8 Direction Selector Switch



WARNING To prevent unexpected vehicle movement when you or other persons next operate the vehicle, ALWAYS place the direction selector switch in the NEUTRAL position when leaving the vehicle seat.

Remove the key to prevent unauthorized use of the vehicle.

Power ON/Battery Condition Meter

The power on/battery condition meter indicates whether power is supplied to the unit and the state of battery charge. The meter illuminates only when power is being supplied.

The meter scale is a 10-bar LED (light emitting diode) displaying the state of charge successively, bar by bar, from full to empty.

- At 70% of discharge, a flashing light signals an “energy reserve” alert.
- At 80% of discharge, a double flashing light signals as “empty” alarm. The batteries should be fully charged before using the vehicle.

Headlight (Accessory)

The headlight can be pivoted on the mounting as required. Push the headlight switch on the dash panel to turn the headlight on or off.

Service/Parking Brake Pedal

The service and parking brakes are combined in the left pedal on the floorboard. Depressing the pedal will slow or stop the vehicle. Once the vehicle has stopped, the parking brake can be engaged by pressing the front portion of the pedal.

The floorboard catch should engage in the first notch of the parking brake lock catch when the brake is properly adjusted. (Ref. Fig. 9 on page 4).

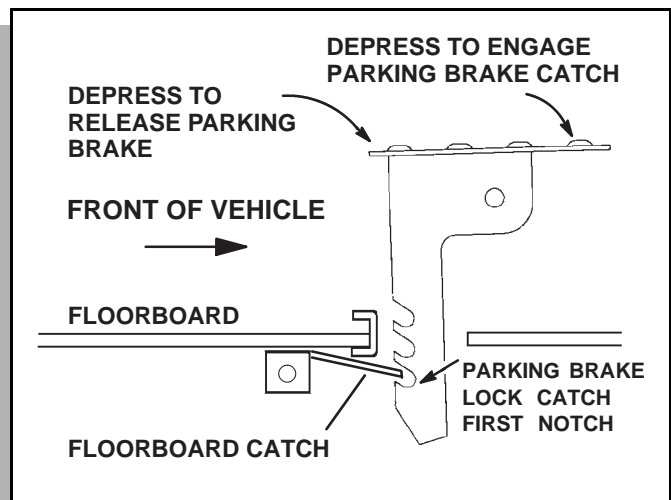

Fig. 9 Speed Control Pedal

To release the parking brake, depress the service/parking brake pedal.

ELECTRIC THREE WHEEL SERVICE VEHICLE

Read all of manual to become thoroughly familiar with this vehicle. Pay particular attention to all Notes, Cautions and Warnings



WARNING *ALWAYS apply the parking brake when the vehicle is to be left unattended. The parking brake is NOT automatically applied.*

Speed Control Pedal

Depressing the speed control pedal starts the motor; releasing the pedal stops the motor.

Operation with the pedal fully depressed gives maximum speed but is recommended only when the vehicle can be operated safely. For slower speeds, depress the pedal as required.



Reverse speed is half of forward speed.



WARNING *To prevent loss of vehicle control, NEVER exceed safe operating speed. ALWAYS adjust speed to conditions.*

Horn and Handlebar

The horn button switch is attached to the handlebar on the standard equipment vehicle.

A vehicle equipped with optional wheel type steering will have the horn button located on the right side of the steering console.

Depress the button to sound the horn. The horn will not sound when the key is in off position.

Handlebar Installation



CAUTION If the handlebar is factory installed, make sure the retaining nut is tight. Otherwise install the fork spindle key, handle, lockwasher and nut. Tighten the nut to 50 ft. lbs. (68 Nm) torque.



WARNING *Failure to install the fork spindle key and to tighten the handlebar retaining nut may allow the handlebar to come loose, resulting in loss of vehicle steering control.*

Seat Switch

The seat switch, located under the operator's seat, allows the vehicle to function only when the seat is in position and the operator is properly seated. Should the operator leave the seat during operation, the vehicle will stop. (Ref. Fig. 10 on page 5).

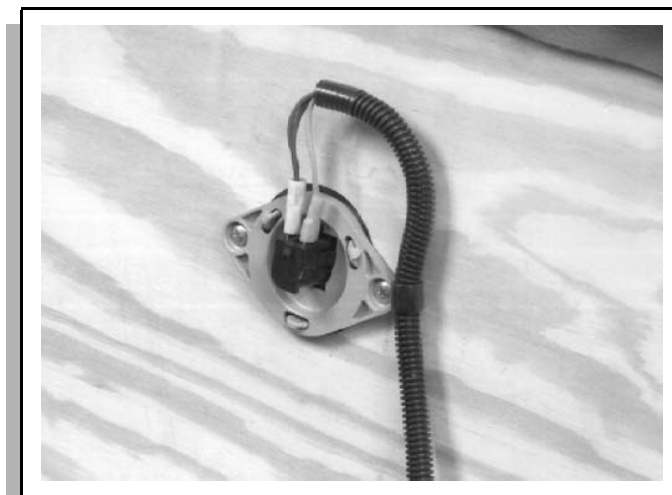

Fig. 10 Seat Switch



WARNING *To prevent unexpected vehicle movement, NEVER operate the vehicle if the seat switch is malfunctioning.*

Hour Meter (Accessory)

The hour meter, located in the motor compartment, behind the speed controller, records the number of hours the vehicle has been operated.

ADDITIONAL FEATURES

Additional features include a built-in battery charger, a fold down backrest and a programmable speed controller.

Battery Charger

The standard vehicle is equipped with a built-in 24 volt, 25 amp DC, 120 volt AC, 60 Hz, fully automatic charger, located under the driver's seat. There is also a storage area under the seat for the charger cord. (Ref Fig. 11 on page 6).

ELECTRIC THREE WHEEL SERVICE VEHICLE

Read all of manual to become thoroughly familiar with this vehicle. Pay particular attention to all Notes, Cautions and Warnings

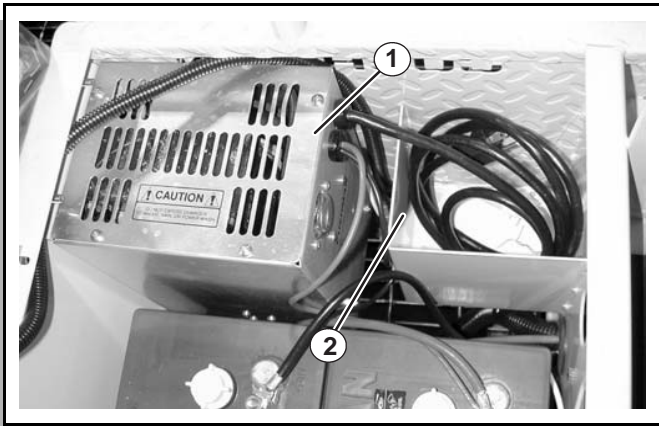

Fig. 11 Battery Charger

Fold Down Backrest

The backrest is easily positioned to provide seating for a passenger or, in a raised position, for cargo.

To lower the backrest, lift it upward and toward the front of the vehicle. When the pins on either side have cleared the slots, slowly lower the backrest into position. Reverse the procedure when raising the backrest. (Ref Fig. 12 on page 6).

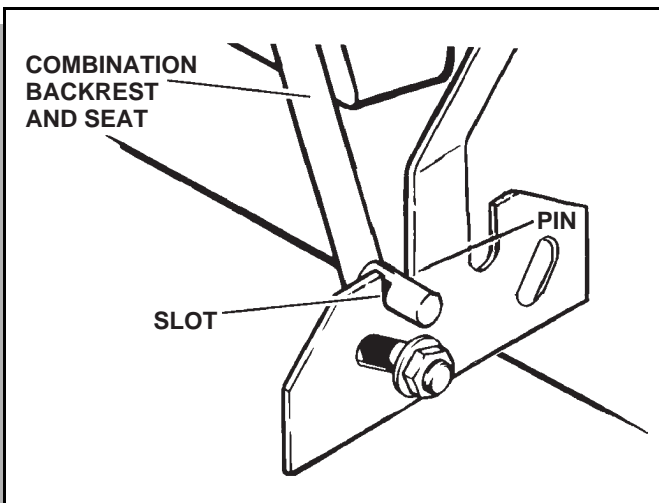

Fig. 12 Fold Down Backrest



WARNING To prevent possible injury, make sure the seat is in the lowered position when carrying a passenger. Raise the seat if no passenger will be carried. DO NOT allow a passenger to stand on the rear step.

Programmable Speed Controller

The vehicle is equipped with a programmable speed controller, which provides a variety of diagnostic data and can be used to change factory speed settings. For information about diagnostics, troubleshooting, adjustments and factory settings, see pages 27 - 30 of this manual.

EE UNITS

This vehicle is available in "EE" versions. "EE" Units meet all the requirements of "E" Units and provide additional safeguards against inherent fire and electrical hazards, as specified per U.L. 583.

The additional components used on "EE" vehicles include:

- head light guard
- rear light guard
- terminal boots for the circuit breaker, motor, and forward, reverse and main solenoids
- a static strap
- a safety hasp to keep the battery compartment securely closed

"EE" Units function identically to "E" Units.

BEFORE ENTERING VEHICLE

1. Check for correct tire inflation.
2. Inspect for fluid leaks.
3. Be sure everything is properly stored and secured.

If vehicle has built-in charger, unplug power cord from electrical outlet and properly store cord under instrument panel prior to moving vehicle. If vehicle has a portable charger, remove charger plug from vehicle receptacle and properly store cable prior to moving vehicle.

OPERATING THE VEHICLE

CAUTION Improper use of the vehicle or the lack of proper maintenance may result in decreased performance or damage to the vehicle.

Read and understand the following warnings before attempting to operate the vehicle:



WARNING To reduce the possibility of severe injury or death resulting from loss of vehicle control, the following warnings must be observed:

ELECTRIC THREE WHEEL SERVICE VEHICLE

Read all of manual to become thoroughly familiar with this vehicle. Pay particular attention to all Notes, Cautions and Warnings

Drive the vehicle only as fast as terrain and safety considerations allow. Consider the terrain, traffic conditions and the environmental factors which effect the terrain and the ability to control the vehicle.

Use extra care and reduced speed when driving on poor surfaces, such as loose dirt, wet grass, gravel, etc.

Avoid extremely rough terrain.

Avoid driving fast down hill. A sudden stop or change of direction may result in loss of control. Use service brake to control speed when traveling down an incline.

Slow down before and during turns. All turns should be executed at reduced speed.

All travel should be directly up or down hills.

Use extra care when driving the vehicle across any incline.

Stay in designated areas and avoid steep slopes. To reduce the possibility of severe injury or death resulting from improper vehicle operation, the following warnings must be observed:

Refer to GENERAL SPECIFICATIONS for capacity.

Make sure that the direction selector is in correct position before attempting to start the vehicle.

Do not take vehicle out of 'gear' while in motion (coast).

Always bring the vehicle to a complete stop before shifting the direction selector.

Check the area behind the vehicle before operating in reverse.

Always hold on while the vehicle is in motion. Keep feet, legs, hands and arms inside the vehicle at all times.

To prevent inadvertent movement when the vehicle is to be left unattended, set parking brake pedal completely, move direction selector switch to neutral position, turn key to 'OFF' position and remove key.

STARTING THE VEHICLE

To start the vehicle: Place the key in the key switch and turn to the 'ON' position. Move the direction selector to

the direction desired, release park brake and press the accelerator pedal to start the vehicle.

NOTE When the direction selector is in the reverse position, a warning signal will sound. This is a device to indicate the vehicle is ready to run in reverse.

Releasing the accelerator slows the vehicle. To stop the vehicle more quickly, depress the brake pedal.

CAUTION To avoid component damage, the vehicle must be brought to a complete stop before shifting the direction selector switch.

Do not hold vehicle on hill by using accelerator and motor. Leaving motor in a stalled condition for more than 3-4 seconds will cause permanent damage to motor.

COASTING

WARNING To prevent injury or death resulting from coasting at above recommended speeds, limit speed with service brake.

On steep hills/ramps, it is possible for vehicles to coast at faster than normal speeds that may be encountered on a flat surface. To prevent loss of vehicle control, speeds should be limited to no more than the maximum speed on level ground (see GENERAL SPECIFICATIONS). Limit speed by releasing the accelerator pedal and applying pressure to the heel of the pedal. Severe damage to the drive train components due to excessive speed may result from driving the vehicle above specified speed. Damage caused by excessive speed may cause a loss of control, is costly, is considered abuse and will not be covered under warranty.

OPERATION

The SAFETY WARNING decal shown is located on the upper portion of the right kick panel. All information on the decal is of the utmost importance. This decal and all others must remain on the vehicle.

WARNING Failure to heed these warnings may result in personal or fatal injury to you or others and may also result in equipment and or property damages.

Before operating vehicle:

Read and understand operator's manual (located under seat).

ELECTRIC THREE WHEEL SERVICE VEHICLE

Read all of manual to become thoroughly familiar with this vehicle. Pay particular attention to all Notes, Cautions and Warnings

All occupants must be seated in factory approved seats, switches spark-do not operate in explosive or commuatable atmosphere.

While operating vehicle:

Keep body inside vehicle passenger must be seated and use hand holds provided.

Sudden sharp turns unbalanced or top heavy loads can cause upset.

Cargo must be secured to platform.

Avoid sudden starts and stops to avoid unseating of passengers.

Adjust speed to conditions.

Before leaving vehicle:

Set direction selector to 'OFF' position.

Turn key to vertical 'OFF' position and remove.

If malfunction occurs, or adjustment is needed, do not use, have all work performed by authorized personnel.

Apply hand or foot brake-not automatically applied.

It is your responsibility to keep all labels (decals) and instructional literature legible and intact.

Replacement labels (decals) and literature are available from the factory.

Your safety and the safety of others around you depends on your conscientious operation of this vehicle. Read the following section carefully and thoroughly to become familiar with proper operating procedures. Be sure to read and understand the following warnings before attempting to operate the vehicle.



understood.

DO NOT operate this vehicle until this owner's manual is read and

DO NOT allow untrained or unauthorized persons to operate this vehicle. NEVER allow children to operate the vehicle.

Before using the equipment, check all parts and any attachments. If a malfunction is found, do not use the vehicle until the problem is corrected.

NEVER carry more than one passenger or a passenger along with a cargo load. Passenger must remain seated in rear at all times during transport.

Passengers MUST NOT stand on rear footrest.

Keep both hands on steering mechanism when ever possible and keep arms and legs inside vehicle while moving. Passenger must use the hand holds provided with the rear seat.



Be aware of object hazards that can impact the operator or passenger within the confines of the vehicle; for example, low hanging tree branches or laterally protruding objects.

Make sure the operating area is clear of debris.

Use extreme care when backing up. Make sure no one is behind you. Back the vehicle carefully at a reasonable speed.

NEVER use the vehicle in or near an area where there is explosive dust or fumes. The electrical system of the unit creates sparks which can ignite explosive materials.

Adjust your speed to current driving conditions.

Travel directly up or down inclines. DO NOT travel across the face of any incline, ramp, grade or slope.

Avoid driving fast down hill. A sudden stop or change of direction can result in loss of control. Use the service brake to control speed when traveling down an incline.

NEVER overload the vehicle. See identification decal on kick panel for rated capacity.

Position loads carefully so they cannot shift or tip over suddenly. Distribute loads evenly over the rear area. Keep loads low to avoid top heaviness.

DRIVING THE VEHICLE

- Make sure you are properly seated in the operator's seat.
- Make sure the direction selector switch is in the NEUTRAL position.
- Apply the parking brake, if it isn't already applied, by depressing the front portion of the service/parking brake pedal.
- Insert the key in the key switch and turn it to the ON position.
- Move the direction selector switch to the desired direction.

ELECTRIC THREE WHEEL SERVICE VEHICLE

Read all of manual to become thoroughly familiar with this vehicle. Pay particular attention to all Notes, Cautions and Warnings

NOTE If the selector is moved to the REVERSE position, a backup warning alarm will sound until the vehicle is again placed in NEUTRAL or FORWARD.

SERVICING THE ELECTRIC VEHICLE

WARNING To prevent severe injury or death, resulting from improper servicing techniques, observe the following Warnings:

Do not attempt any type of servicing operations before reading and understanding all notes, cautions and warnings in this manual.

Any servicing requiring adjustments to be made to the powertrain while the motor is running must be made with the entire vehicle raised.



Wear eye protection when working on the vehicle. In particular, use care when working around batteries, or using solvents or compressed air.

To reduce the possibility of causing an electrical arc, which could result in a battery explosion, turn off all electrical loads from the batteries before removing any heavy gauge battery wires.

To prevent the possibility of motor disintegration, never operate vehicle at full throttle for more than 4 - 5 seconds while vehicle is in a "no load" condition.

Battery posts, terminals and related accessories contain lead and lead compounds. Wash hands after handling.

It is in the best interest of both vehicle owner and servicing dealer to carefully follow the procedures recommended in this manual. Adequate preventative maintenance, applied at regular intervals, is the best guarantee for keeping the vehicle both dependable and economical.

TOWING

WARNING This vehicle is not designed to be towed.

It is recommended that this vehicle be moved by placing the entire vehicle on a trailer, flatbed truck or other suitable transport.

LIFTING THE VEHICLE

Tool List	Qty. Required
Floor jack.....	1
Jack stands	4
Chocks	4
Chain hoist	1

Some servicing operations may require the vehicle be raised.

WARNING To prevent possible injury or death resulting from a vehicle falling from a jack, be sure the vehicle is on a firm and level surface. Never get under a vehicle while it is supported by a jack. Use jack stands and test the stability of the vehicle on the stands. Always place chocks in front and behind the wheels not being raised. Use extreme care since the vehicle is extremely unstable during the lifting process.

Never attempt to raise the rear wheels of a three wheel vehicle without first raising the front of the vehicle and supporting on jack stands.

CAUTION When lifting vehicle, position jacks and jack stands only on the areas indicated.

Due to the low ground clearance and short wheel base, the vehicle should only be raised enough to remove the front axle or the rear wheels. Servicing that requires access to the underside of the vehicle should be accomplished by raising the front of the vehicle with a chain hoist attached to the front frame members. Always use an additional safety chain to prevent injury should the hoist malfunction.

To remove a wheel or the front axle, loosen the hardware. Position a jack in the location indicated and carefully raise the front of the vehicle. Position the jack stands as shown. Use care not to place the jack or stands where they could interfere with wiring or linkages. Slowly lower the jack and test the stability of the vehicle.

To raise the rear of the vehicle, first raise the front of the vehicle as previously described and support on jack stands. Then position the jack in the position shown at the rear of the vehicle. Carefully raise the rear of the vehicle with the jack and place two jack stands in the position shown. Slowly lower the jack and check that the vehicle is securely supported by the jack stands before proceeding.

Lower the vehicle by reversing the lifting sequence.

ELECTRIC THREE WHEEL SERVICE VEHICLE

Read all of manual to become thoroughly familiar with this vehicle. Pay particular attention to all Notes, Cautions and Warnings

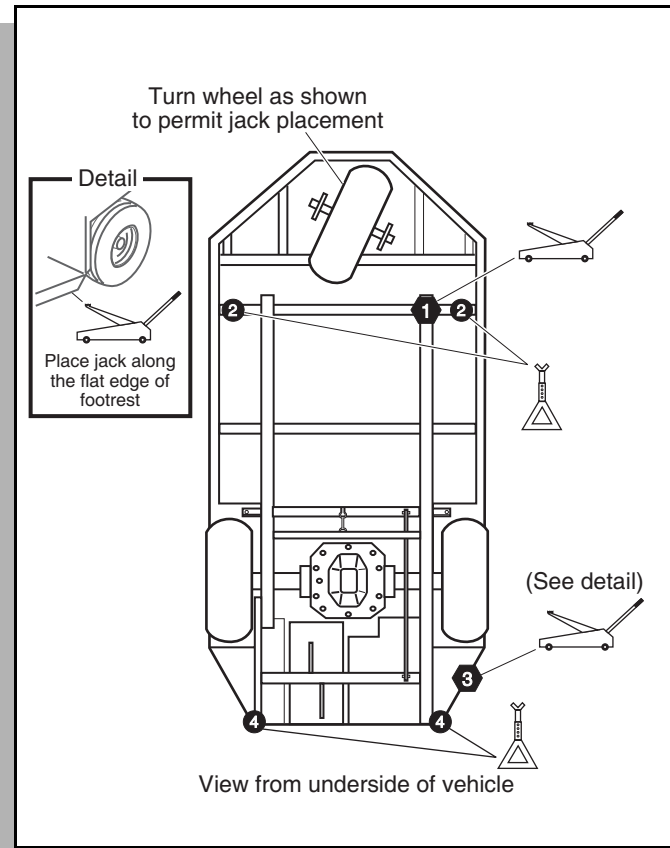

Fig. 13 Lifting the Vehicle

SAFETY COMPONENTS

The vehicle electrical circuit includes two protective components: a seat switch and a thermal circuit breaker.

Seat Switch

Removing body weight from the vehicle seat will cause the seat switch to interrupt electrical power to the controller. You must remain seated during vehicle operation.

Thermal Circuit Breaker

The thermal circuit breaker prevents overloading of the drive motor. Should the vehicle be stopped by the opening of the circuit breaker, turn the vehicle off to avoid an accidental start when the breaker resets. The breaker automatically resets after approximately 20 seconds. An audible click will sound when the breaker resets.

If the circuit breaker continues to open, a problem exists within the circuit or the vehicle is overloaded. Do not operate the vehicle until the problem is resolved.

⚠ WARNING ⚠ If the circuit breaker should open while driving on an incline, immediately apply the service and parking brakes to prevent loss of vehicle control.

Parking The Vehicle

To park the vehicle, complete the following steps before leaving the operator's seat:

1. Stop the vehicle and move the direction selector switch to the NEUTRAL position.
2. Apply the parking brake.
3. Turn the key switch to the vertical OFF position and remove the key.

NOTE When parking the vehicle on an incline, the front wheel should be curbed whenever possible. (Ref Fig. 14 on page 10).

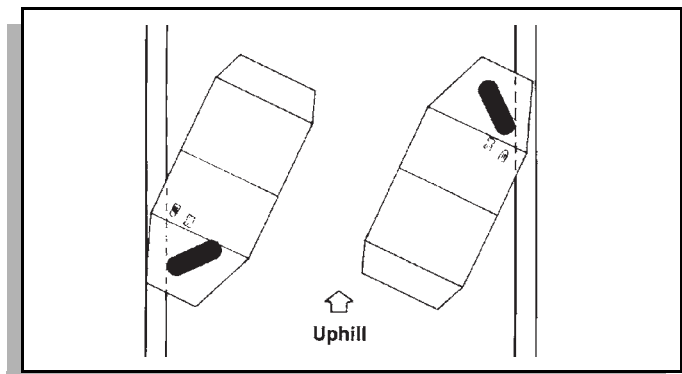

Fig. 14 Parking The Vehicle

ROUTINE MAINTENANCE

This vehicle will give years of satisfactory service, providing it receives regular maintenance. Refer to the Periodic Service Schedule for appropriate service intervals (Ref Fig. 22 on page 16). Refer to Lubrication Points for appropriate lubrication locations (Ref Fig. 15 on page 11).

NOTE Some maintenance items must be serviced more frequently on vehicles used under severe driving conditions.

CAUTION Use maximum of three pumps of grease for each grease fitting - Overgreasing may damage grease seals.

Putting more than three pumps of grease in a grease fitting could damage grease seals and cause premature bearing failure.

ELECTRIC THREE WHEEL SERVICE VEHICLE

Read all of manual to become thoroughly familiar with this vehicle. Pay particular attention to all Notes, Cautions and Warnings

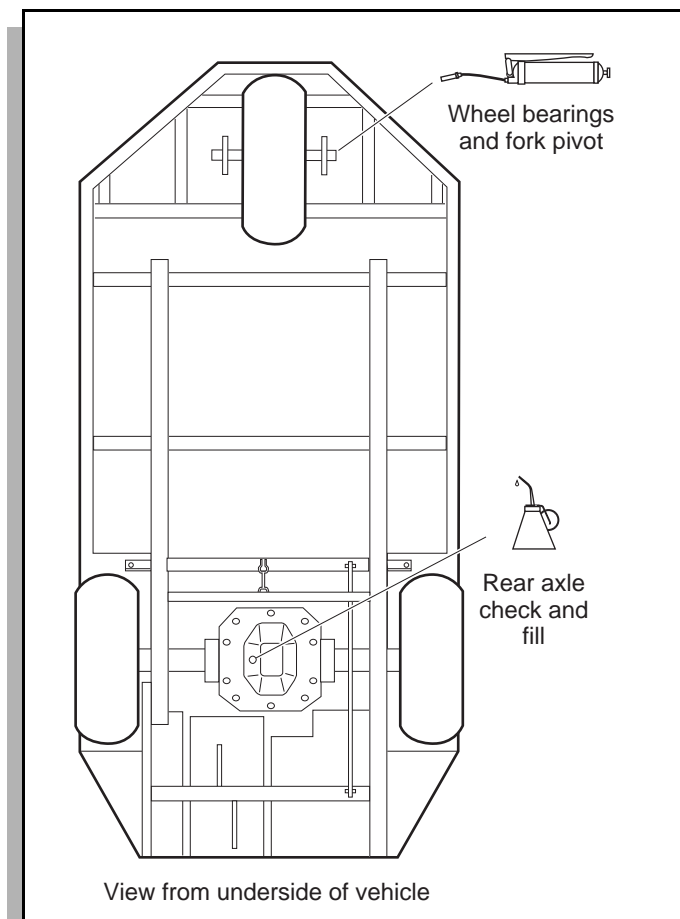

Fig. 15 Lubrication Points

REAR AXLE

The only maintenance required for the first five years is the periodic inspection of the lubricant level. The rear axle is provided with a lubricant level check/fill plug located on the bottom of the differential. Unless leakage is evident, the lubricant need only be replaced after five years.

Checking the Lubricant Level

With the vehicle on level ground, clean the area around the check/fill plug and remove plug (Ref Fig. 16 on page 11). The correct lubricant level is just below the bottom of the threaded hole. If lubricant is low, add as required. Add lubricant slowly until lubricant starts to seep from the hole. Install the check/fill plug. In the event that the lubricant is to be replaced, the vehicle must be elevated and the oil pan removed or the oil siphoned out through the check/fill hole.

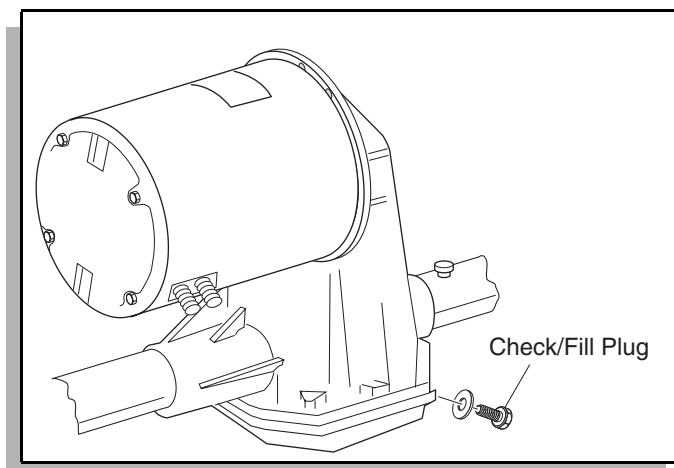

Fig. 16 Rear Axle Lubricant Check and Fill

BRAKES

Service brakes in accordance with the Periodic Service Schedule (Ref Fig. 22 on page 16). After the vehicle has been put into service, it is recommended that the brakes be checked by performing the following test:

Test Method



To prevent severe injury or death resulting from operating a vehicle with improperly operating brake system, the braking system must be properly maintained. All driving brake tests must be done in a safe location with regard for the safety of all personnel.



Over time, a subtle loss of performance may take place. Therefore, it is important to establish the normal braking distance with a new vehicle.

Determine the braking performance of the vehicle by engaging the parking brake at a **common point** on a flat, dry, clean paved surface while traveling at maximum speed (Ref Fig. 17 on page 12). Observe the vehicle stopping location. If the vehicle stops in a significantly greater distance than normal or pulls to one side, it should be tested again.

If the vehicle fails the second test, it should **immediately** be removed from service. The vehicle needs to be inspected by a qualified mechanic.

ELECTRIC THREE WHEEL SERVICE VEHICLE

Read all of manual to become thoroughly familiar with this vehicle. Pay particular attention to all Notes, Cautions and Warnings

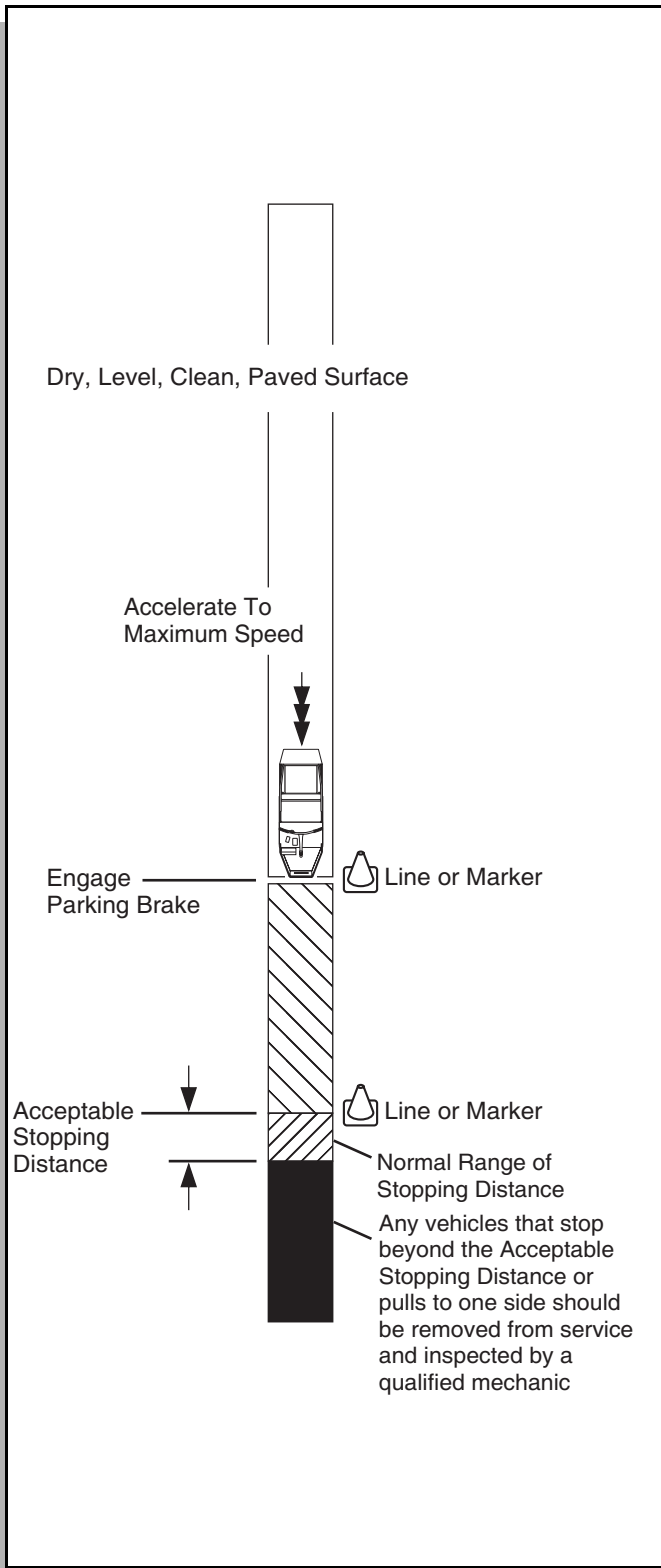

Fig. 17 Periodic Brake Performance Test

TIRES

Tools List	Qty. Required
Impact wrench, 1/2" drive	1
Impact socket, 3/4", 1/2" drive	1
Torque wrench, 1/2" drive, ft. lbs.	1
Wrench, 1 1/8"	2

⚠ WARNING ⚠ *To prevent injury caused by a broken socket, use only sockets designed for impact wrench use. Never use a conventional socket.*

Tire condition should be inspected per the Periodic Service Schedule (Ref. Fig. 22 on page 16). Inflation pressures should be checked when the tires are cool. When removing wheels with an impact wrench, use only impact sockets. Regular sockets are not designed for impact pressures exerted by power tools.

⚠ WARNING ⚠ *A tire explosion can cause severe injury or death. Never exceed inflation pressure rating on tire sidewall.*

To prevent tire explosion, pressurize tire with small amount of air applied intermittently to seat beads. Never exceed the tire manufacturer's recommendation when seating a bead. Protect face and eyes from escaping air when removing valve core.

Use caution when inflating tires. Due to the low volume of these small tires, overinflation can occur in a matter of seconds. Overinflation could cause the tire to separate from the wheel or cause the tire to explode, either of which could cause personal injury.

Use caution when inflating tires. Due to the low volume of these small tires, overinflation can occur in a matter of seconds. Overinflation could cause the tire to separate from the rim or cause the tire to explode, either of which could cause personal injury.

See GENERAL SPECIFICATIONS section for recommended tire inflation pressure. Under no condition should inflation pressure be higher than recommended on tire sidewall. **All three tires** should have the same pressure for optimum handling characteristics. Be careful not to overinflate. Due to the low volume of these small tires, overinflation can occur in a matter of seconds. Be sure to install the valve dust cap after checking or inflating.

ELECTRIC THREE WHEEL SERVICE VEHICLE

Read all of manual to become thoroughly familiar with this vehicle. Pay particular attention to all Notes, Cautions and Warnings

Tire Repair

The vehicle is fitted with tubeless tires mounted on one piece rims.

Generally, the most cost effective way to repair a flat tire resulting from a puncture in the tread portion of the tire is to use a commercial tire plug.

NOTE *Tire plug tools and plugs are available at most automotive parts outlets and have the advantage of not requiring the tire be removed from the rim.*

If the tire is flat, remove the wheel and inflate the tire to the maximum recommended pressure for the tire. Immerse the tire in water to locate the leak and mark with chalk. Insert tire plug in accordance with manufacturer's specifications.

If tire is to be removed from or mounted on rim, the tire changing machine manufacturer's recommendations must be followed to reduce possibility of personal injury.

⚠ WARNING ⚠ *To prevent injury, be sure mounting/demounting machine is anchored to floor. Wear OSHA approved safety equipment when mounting/demounting tires.*

Follow all instructions and safety warnings provided by the mounting/demounting machine manufacturer.

Wheel Installation

CAUTION Do not tighten lug nuts to more than 85 ft. lbs. (115 Nm) torque.

NOTE *It is important to follow the 'cross sequence' pattern when installing lug nuts. This will assure even seating of the wheel against the hub.*

With the valve stem to the outside, mount the wheel onto the hub with lug nuts. Finger tighten lug nuts in a 'cross sequence' pattern (Ref Fig. 18 on page 13). Then, tighten lug nuts to 50 - 85 ft. lbs. (70 - 115 Nm) torque in 20 ft. lbs. (30 Nm) increments following the same 'cross sequence' pattern.

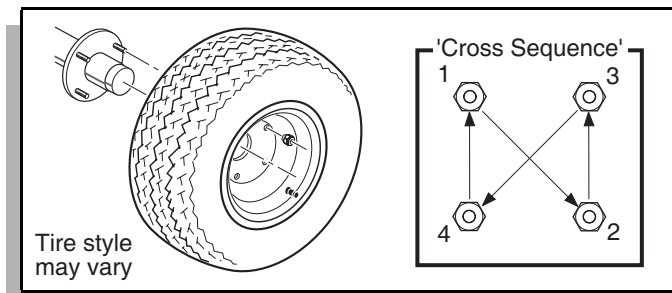

Fig. 18 Wheel Installation

Removing and Reinstalling Front Tire

To remove and reinstall the front tire, complete the following steps and (Ref. Fig. 19 on page 13).

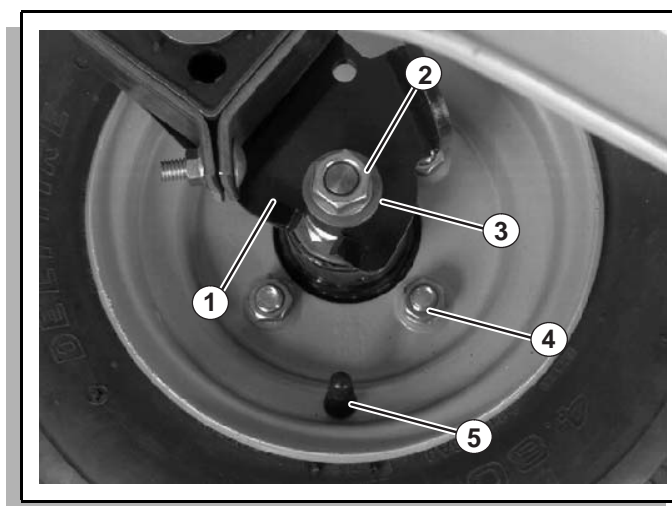

Fig. 19 Wheel Installation

1. Front Axle Lock
 2. Axle Nut
 3. Retaining Washer
 4. Wheel Retaining Nut
 5. Valve Stem
1. Loosen the axle nuts and lower entire wheel, hub and axle assembly from front fork. Remove the four wheel retaining nuts.
 2. Completely deflate the tire, then remove from wheel.
 3. Reinstall tire and wheel by reversing the above sequence and tighten wheel retaining nuts. Tighten to 70 to 80 ft. lbs. (95 to 108.5 Nm) torque.
 4. Position the large flat washer located on the ends of the axle above the front axle locks.
 5. Tighten axle nuts to 100 to 120 ft. lbs. (130 to 156 Nm) torque.

ELECTRIC THREE WHEEL SERVICE VEHICLE

Read all of manual to become thoroughly familiar with this vehicle. Pay particular attention to all Notes, Cautions and Warnings

NOTE Install the wheel assembly with the valve stem on the same side as the wheel retaining nuts.



To prevent possible injury, always deflate the tire completely before removing from the wheel.

When reinstalling the front wheel assembly, always place the axle and retaining washer over the axle locks (as shown) and tighten the axle nuts. Tighten axle nuts to 100 to 120 ft. lbs. (130 to 156 Nm) torque. Failure to follow the procedure may allow the axle to drop, resulting in loss of vehicle control.

Removing and Reinstalling Rear Tire

1. Remove the wheel retaining nuts and remove the wheel assembly from the hub.
2. Completely deflate the tire, then remove from wheel.
3. Reinstall the tire and wheel by reversing above sequence and tighten wheel retaining nuts. Tighten to 70 to 80 ft. lbs. (95 to 108.5 Nm) torque.
4. Make sure the valve stem is located toward the outside.

LIGHT BULB REPLACEMENT

To replace the headlight bulb, pivot the headlight forward and remove the two Phillips head screws from back side and separate light assembly. Place new light bulb in place and secure with screws previously removed.

To replace the taillight bulb, remove hardware securing lens and remove lens. Install replacement bulb.

CARE AND CLEANING OF THE VEHICLE

CAUTION To prevent cosmetic damage, do not use any abrasive or reactive solvents to clean plastic parts.

It is important that proper techniques and cleaning materials be used.

Normal cleaning of the vinyl backrest and plastic or rubber trim requires the use of a mild soap solution applied with a sponge or soft brush and wipe with a damp cloth.

Removal of oil, tar, asphalt, shoe polish, etc. will require the use of a commercially available vinyl/rubber cleaner.

The painted surfaces of the vehicle provide attractive appearance and durable protection. Frequent washing

with lukewarm or cold water is the best method of preserving the painted surfaces.

Do not use hot water, strong soap or harsh chemical detergents.

Rubber parts should be cleaned with nonabrasive household cleaner.

Occasional cleaning and waxing with nonabrasive products designed for 'clear coat' automotive finishes will enhance the appearance and durability of the painted surfaces.

Corrosive materials used for dust control can collect on the underbody of the vehicle. These materials will accelerate corrosion of underbody parts. It is recommended that the underbody be flushed occasionally with plain water. Thoroughly clean any areas where mud or other debris can collect. Sediment packed in closed areas should be loosened to ease its removal, taking care not to chip or otherwise damage paint.

TRAILERING



To prevent personal injury to occupants of other highway vehicles, be sure that the vehicle and contents are adequately secured to trailer.

Do not ride on vehicle being trailered.

Always check that the vehicle and contents are adequately secured before trailering the vehicle. The rated capacity of the trailer must exceed the weight of the vehicle and load plus 400 pounds (180 kg) (see GENERAL SPECIFICATIONS section for vehicle weight). Secure the vehicle to the trailer using ratchet tie downs.

ELECTRIC THREE WHEEL SERVICE VEHICLE

Read all of manual to become thoroughly familiar with this vehicle. Pay particular attention to all Notes, Cautions and Warnings

HARDWARE

Periodically, the vehicle should be inspected for loose fasteners. Fasteners should be tightened in accordance with the Torque Specifications table (Ref Fig. 21 on page 15). Use care when tightening fasteners and refer to the Technician's Repair and Service Manual for specific torque values.

Generally, two grades of hardware are used in the vehicle. Grade 5 hardware can be identified by the three marks on the hexagonal head. Unmarked hardware is

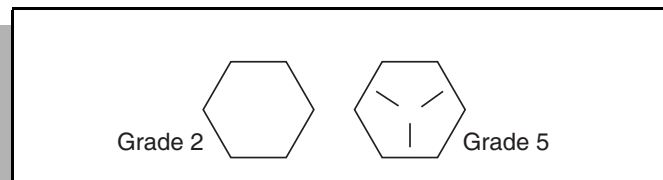

Fig. 20 Bolt Grades

TORQUE SPECIFICATIONS

ALL TORQUE FIGURES ARE IN FT. LBS. (Nm)											
Unless otherwise noted in text, tighten all hardware in accordance with this chart.											
This chart specifies 'lubricated' torque figures. Fasteners that are plated or lubricated when installed are considered 'wet' and require approximately 80% of the torque required for 'dry' fasteners.											
BOLT SIZE		1/4"	5/16"	3/8"	7/16"	1/2"	9/16"	5/8"	3/4"	7/8"	1"
Grade 2		4 (5)	8 (11)	15 (20)	24 (33)	35 (47)	55 (75)	75 (102)	130 (176)	125 (169)	190 (258)
Grade 5		6 (8)	13 (18)	23 (31)	35 (47)	55 (75)	80 (108)	110 (149)	200 (271)	320 (434)	480 (651)
Grade 8		6 (8)	18 (24)	35 (47)	55 (75)	80 (108)	110 (149)	170 (230)	280 (380)	460 (624)	680 (922)
BOLT SIZE		M4	M5	M6	M8	M10	M12	M14			
Class 5.8 (Grade 2)		1 (2)	2 (3)	4 (6)	10 (14)	20 (27)	35 (47)	55 (76.4)			
Class 8.8 (Grade 5)		2 (3)	4 (6)	7 (10)	18 (24)	35 (47)	61 (83)	97 (131)			
Class 10.9 (Grade 8)		3 (4)	6 (8)	10 (14)	25 (34)	49 (66)	86 (117)	136 (184)			

Ref Tsp 1

Fig. 21 Torque Specifications

ELECTRIC THREE WHEEL SERVICE VEHICLE

Read all of manual to become thoroughly familiar with this vehicle. Pay particular attention to all Notes, Cautions and Warnings

PERIODIC SERVICE SCHEDULE

✓ Check † Clean, Adjust, etc. ▲ Replace NOTE: Some maintenance items must be serviced more frequently on vehicles used under severe driving conditions	
DAILY	
BODY	† Clean body components as required
REVERSE WARNING DEVICE	✓ Check operation when direction selector is in reverse
TIRES	✓ Examine for cuts, excessive wear and pressure (See GENERAL SPECIFICATIONS)
WHEELS	✓ Check for bent rims, missing or loose lug nuts
BATTERIES	† Recharge to full state of charge after each day's use
MONTHLY - 20 HOURS (includes items listed in previous table & the following)	
BATTERIES	† Clean batteries & terminals with 1/4 cup (60 ml) baking soda to 1 1/2 gallons (6 liters) water solution, rinse with clear water ✓ Check charge condition and all connections
SERVICE/ PARK BRAKE	✓ Check brake performance, smooth operation † Adjust if required
WIRING	✓ Check all wiring for loose connections and broken/missing insulation
ACCELERATOR	✓ Check for smooth movement
STEERING	✓ Check for excessive play, tightness of all hardware and bent or loose components
REAR AXLE	✓ Check for oil leakage, add lubricant (SAE 80-90 oil) as required 10 Oz (.3L) Capacity.
QUARTERLY - 50 HOURS (includes items listed in previous tables & the following)	
FRONT FORK	✓ Check for damage to axle and loose or missing hardware
FRONT WHEEL ALIGNMENT	✓ Check for unusual tire wear, align if required
SERVICE / PARK BRAKE	✓ Check for bent/binding linkage rods ✓ Check for damage or wear

Fig. 22 Periodic Service Schedule

ELECTRIC THREE WHEEL SERVICE VEHICLE

Read all of manual to become thoroughly familiar with this vehicle. Pay particular attention to all Notes, Cautions and Warnings

BATTERIES AND CHARGING

Safety

NOTE

Always observe the following warnings when working on or near batteries:

WARNING

To prevent burns or battery explosion that could result in severe personal injury or death, keep all smoking materials, open flame or sparks away from the batteries.

Hydrogen gas is formed when charging batteries. Do not charge batteries without adequate ventilation. A 4% concentration of hydrogen gas is explosive.

Be sure that the key switch is off and all electrical accessories are turned off before starting work on vehicle.

Never disconnect a circuit under load at a battery terminal.



Batteries are heavy. Use proper lifting techniques when moving them. Always lift the battery with a commercially available battery lifting device. Use care not to tip batteries when removing or installing them; spilled electrolyte can cause burns and damage.

The electrolyte in a storage battery is an acid solution which can cause severe burns to the skin and eyes. Treat all electrolyte spills to the body and eyes with extended flushing with clear water. Contact a physician immediately.



Always wear a safety shield or approved safety goggles when adding water or charging batteries.

Any electrolyte spills should be neutralized with a solution of 1/4 cup (60 ml) sodium bicarbonate (baking soda) dissolved in 1 1/2 gallons (6 liters) of water and flushed with water.

Overfilling batteries may result in electrolyte being expelled from the battery during the charge cycle. Expelled electrolyte may cause personal injury and damage to the vehicle and storage facility.

At Each Charging Cycle



Wrap wrenches with vinyl tape to prevent the possibility of a dropped wrench from 'shorting out' a battery, which could result in an explosion and severe personal injury or death.

Aerosol containers of battery terminal protectant must be used with extreme care. Insulate metal container to prevent can from contacting battery terminals which could result in an explosion.

BATTERY

A battery is defined as two dissimilar metals immersed in an acid. If the acid is absent or if the metals are not dissimilar, a battery has not been created. The batteries most commonly used in these vehicles are lead acid.

A battery does not store electricity, but is able to produce electricity as the result of a chemical reaction which releases stored chemical energy in the form of electrical energy. The chemical reaction takes place faster in warm conditions and slower in cold conditions. Temperature is important when conducting tests on a battery and test results must be corrected to compensate for temperature differences.

As a battery ages, it still performs adequately except that its **capacity** is diminished. Capacity describes the time that a battery can continue to provide its design amperes from a full charge.

A battery has a maximum life, therefore good maintenance is designed to maximize the **available** life and reduce the factors that can reduce the life of the battery.

BATTERY MAINTENANCE

Tool List

Qty. Required

Insulated wrench, 9/16"	1
Battery carrier	1
Hydrometer P/N 50900-G1	1
Battery maintenance kit P/N 25587-G01	1

ELECTRIC THREE WHEEL SERVICE VEHICLE

Read all of manual to become thoroughly familiar with this vehicle. Pay particular attention to all Notes, Cautions and Warnings



To reduce the possibility of fire, never attach a battery charger to a vehicle that is to be unattended beyond the normal charging cycle. Overcharging could cause damage to the vehicle batteries and result in extreme overheating. The charger should be checked after 24 hours and unplugged after the charge cycle is complete.

Before charging the batteries, inspect all plugs/receptacles of the battery charging system for dirt or debris.

Charge the batteries after each days use.

Monthly

- Inspect all wiring for fraying, loose terminations, corrosion or deterioration of insulation.
- Check that the electrolyte level is correct and add suitable water as required.
- Clean the batteries and wire terminations.

Electrolyte Level and Water

The correct level of the electrolyte is 1/2" (13 mm) above the plates in each cell (Ref Fig. 23 on page 19).

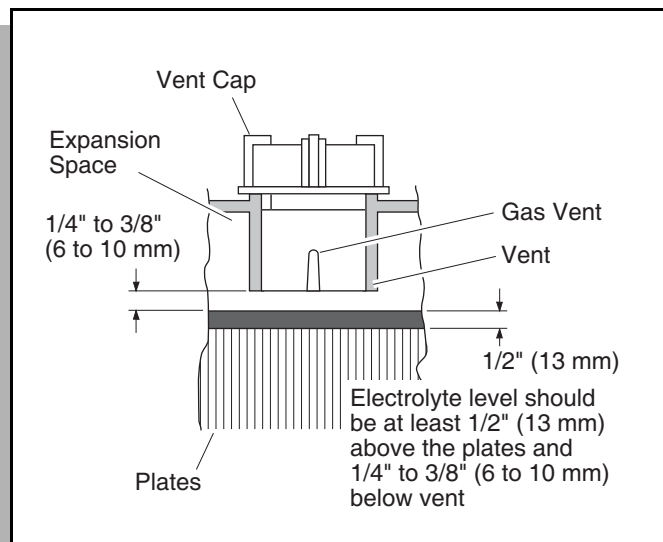

Fig. 23 Correct Electrolyte Level

This level will leave approximately 1/4" - 3/8" (6 - 10 mm) of space between the electrolyte and the vent tube. The electrolyte level is important since **any portion** of the plates exposed to air will be ruined beyond repair. Of equal importance is too much water which will result in electrolyte being forced out of the battery due to gassing and the increase in volume of the electrolyte that results from the charging cycle.



Do not overfill batteries. The charging cycle will expel electrolyte and result in component damage.

A battery being charged will 'gas' with the majority of the gassing taking place at the end of the charging cycle. This gas is hydrogen which is lighter than air. Water and sulfuric acid droplets will be carried out of the battery vents by the hydrogen gas; however, this loss is minimal. If the battery electrolyte level is too high, the electrolyte will block the vent tube and the gas will **force** it out of the vent tube and battery cap. The water will evaporate but the sulfuric acid will remain where it can damage vehicle components and the storage facility floor. Sulfuric acid loss will weaken the concentration of acid within the electrolyte and reduce the life of the battery.

Over the life of the battery, a considerable amount of water is consumed. It is important that the water used be pure and free of contaminants that could reduce the life of the battery by reducing the chemical reaction. The water must be distilled or purified by an efficient filtration system. Water that is not distilled should be analyzed and if required, filtration installed to permit the water to meet the requirements of the water purity table (Ref Fig. 24 on page 19).

Impurity	Parts Per Million
Color	Clear
Suspended.....	Trace
Total Solids.....	100
Calcium & Magnesium Oxides.....	40
Iron.....	5
Ammonia.....	8
Organic & Volatile Matter.....	50
Nitrites.....	5
Nitrates	10
Chloride	5

Fig. 24 Water Purity Table

Even if the water is colorless, odorless, tasteless and fit for drinking, the water should be analyzed to see that it does not exceed the impurity levels specified in the table.

Automatic watering devices such as the one included in the Battery Maintenance Kit can be used with an approved water source (Ref Fig. 25 on page 20). These watering devices are **fast and accurate** to use and

ELECTRIC THREE WHEEL SERVICE VEHICLE

Read all of manual to become thoroughly familiar with this vehicle. Pay particular attention to all Notes, Cautions and Warnings

maintain the correct electrolyte level within the battery cells.

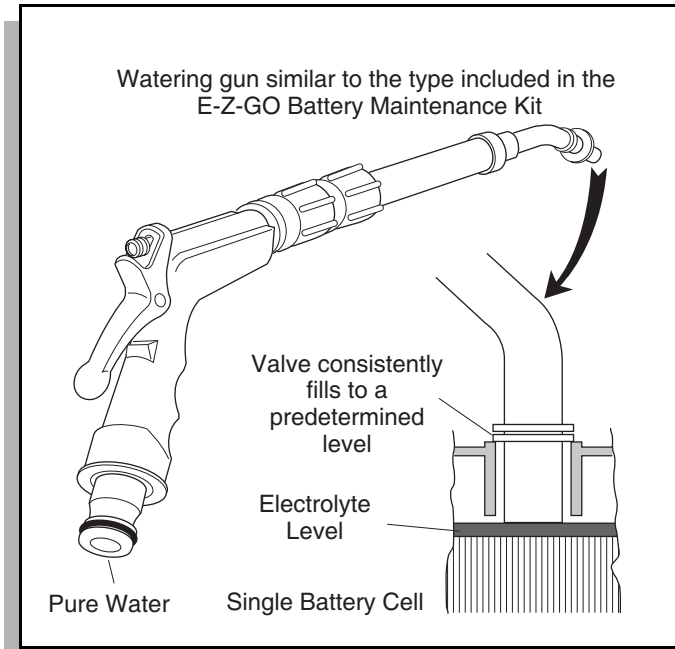

Fig. 25 Automatic Watering Gun

NOTE The watering device should only be used if the electrolyte level is less than 1/2" (13 mm) above top of plates.

Cleaning Batteries

When cleaning the outside of the batteries and terminals, do not use a water hose without first spraying with a solution of sodium bicarbonate (baking soda) and water to neutralize any acid deposits.

Use of a water hose without first neutralizing any acid, will move acid from the top of the batteries to another area of the vehicle or storage facility where it will attack the metal structure or the concrete/asphalt floor. After hosing down the batteries, a residue will be left on the batteries which is conductive and will contribute to the discharge of the batteries.

CAUTION To prevent battery damage, be sure that all battery caps are tightly installed.

The correct cleaning technique is to spray the top and sides of the batteries with a solution of sodium bicarbonate (baking soda) and water. This solution is best applied with a garden type sprayer equipped with a **non metallic spray wand**. The solution should consist of 1/4 cup (60 ml) of sodium bicarbonate (baking soda) mixed with 1 1/2 gallons (6 liters) of clear water (Ref Fig. 26 on page 20).

In addition to the batteries, special attention should be paid to metallic components adjacent to the batteries which should also be sprayed with the sodium bicarbonate (baking soda) solution.

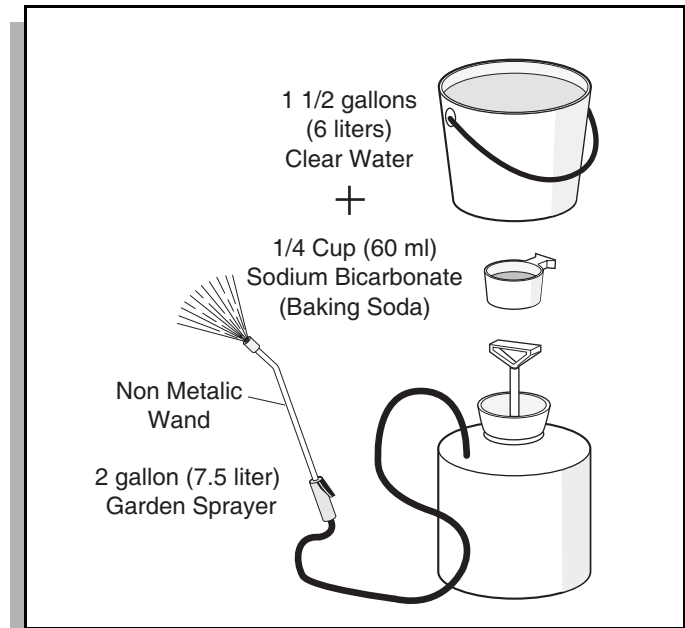

Fig. 26 Preparing Acid Neutralizing Solution

Allow the solution to sit for at least three minutes; use a soft bristle brush or cloth to wipe the tops of the batteries in order to remove any residue that could cause the self discharge of the battery. Rinse the entire area with low pressure clear water. All of the items required for complete battery cleaning and watering are contained in the Battery Maintenance Kit.

Cleaning should take place once a month or more often under extreme conditions.

Battery Replacement

Remove battery hold downs and cables. Lift out batteries with a commercially available lifting device.

If the batteries have been cleaned and any acid in the battery rack area neutralized as recommended, no corrosion to the battery racks or surrounding area should be present. Any corrosion found should be immediately removed with a putty knife and a wire brush. The area should be washed with a solution of sodium bicarbonate (baking soda) and water and thoroughly dried before priming and painting with a corrosion resistant paint.

The batteries should be placed into the battery racks and the battery hold downs tightened to 45 - 55 in. lbs. (5 - 6

ELECTRIC THREE WHEEL SERVICE VEHICLE

Read all of manual to become thoroughly familiar with this vehicle. Pay particular attention to all Notes, Cautions and Warnings

Nm) torque, to prevent movement but not tight enough to cause distortion of the battery cases.

Inspect all wires and terminals. Clean any corrosion from the battery terminals or the wire terminals with a solution of sodium bicarbonate (baking soda) and brush clean if required.

⚠ WARNING ⚠ *To prevent battery explosion that could result in severe personal injury or death, extreme care must be used with aerosol containers of battery terminal protectant. Insulate the metal container to prevent the metal can from contacting battery terminals which could result in an explosion.*

Use care to connect the battery wires as shown (Ref. Fig. 27 on page 21). Tighten the battery post hardware to 50 - 70 in. lbs. (6 - 8 Nm) torque. Protect the battery terminals and battery wire terminals with a commercially available protective coating.

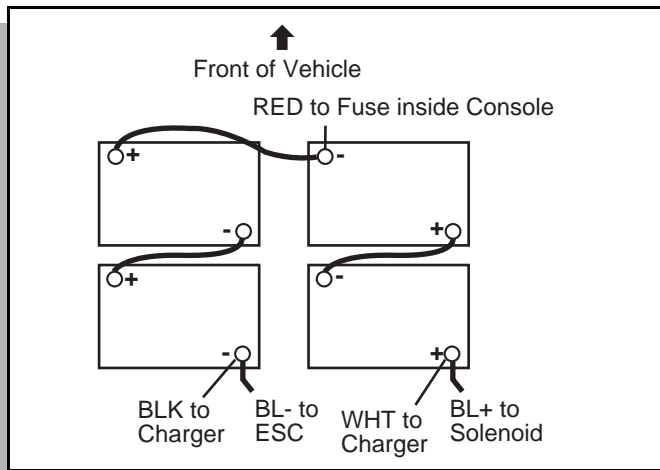

Fig. 27 Battery Connections

Prolonged Storage

CAUTION Battery charger and controller must be disconnected since they will contribute to the premature discharge of batteries. Other electronic devices may need to be disconnected.

During periods of storage, the batteries will need attention to keep them maintained and prevent discharge.

In high temperatures the chemical reaction is faster, while low temperatures cause the chemical reaction to slow down. A vehicle that is stored at 90° F (32° C) will lose .002 of specific gravity each day. If a fully charged battery has a specific gravity of 1.275, and the battery is

allowed to sit unused, it will become partially discharged. When it reaches 1.240, which it will do in less than twenty days, it should be recharged. If a battery is left in a discharged state, sulfating takes place on and within the plates. This condition is not reversible and will cause permanent damage to the battery. In order to prevent damage, the battery should be recharged. A hydrometer can be used to determine the specific gravity and therefore the state of charge of a battery.

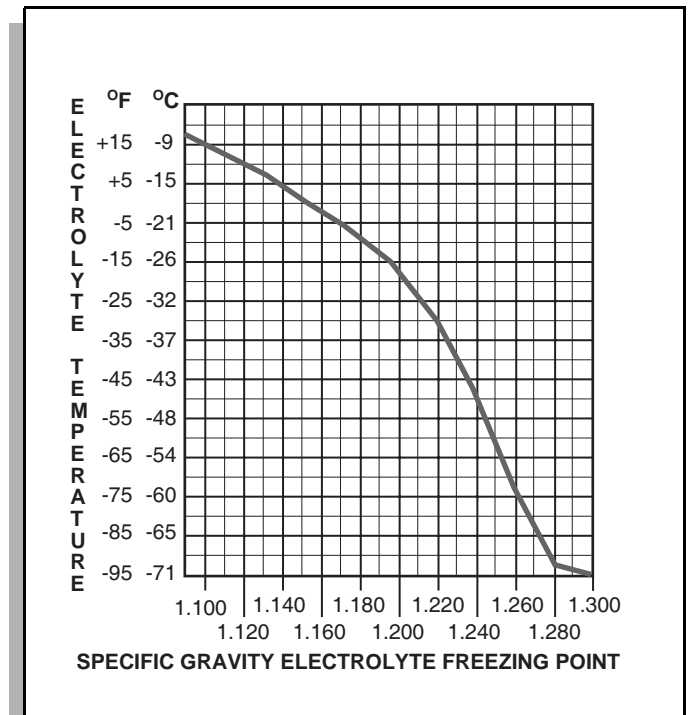

Fig. 28 Freezing Point of Electrolyte

In winter conditions, the battery must be fully charged to prevent the possibility of freezing (Ref Fig. 28 on page 21). A fully charged battery will not freeze in temperatures above -75° F (-60° C). Although the chemical reaction is slowed in cold temperatures, the battery must be stored fully charged, and disconnected from any circuit that could discharge the battery. For portable chargers, disconnect the charging plug from the vehicle receptacle. For on-board chargers, disconnect the charging harness from the batteries. The batteries must be cleaned and all deposits neutralized and removed from the battery case to prevent self discharge. The batteries should be tested or recharged at thirty day minimum intervals.

Battery Charging

The battery charger is designed to fully charge the battery set. If the batteries are severely deep cycled, some

ELECTRIC THREE WHEEL SERVICE VEHICLE

Read all of manual to become thoroughly familiar with this vehicle. Pay particular attention to all Notes, Cautions and Warnings

automatic battery chargers contain an electronic module that may not activate and the battery charger will not function. Automatic chargers will determine the correct duration of charge to the battery set and will shut off when the battery set is fully charged. Always refer to the instructions of the specific charger used.

Before charging, the following should be observed:

CAUTION Do not overfill batteries. The charging cycle will expel electrolyte and result in component damage.

- The electrolyte level in all cells must be at the recommended level and cover the plates.
- The charging must take place in an area that is well ventilated and capable of removing the hydrogen gas that is generated by the charging process. A **minimum** of five air exchanges per hour is recommended.
- The charging connector components are in good condition and free from dirt or debris.
- The charger connector is fully inserted into the vehicle receptacle.
- The charger connector/cord set is protected from damage and is located in an area to prevent injury that may result from personnel running over or tripping over the cord set.
- The charger is automatically turned off during the connect/disconnect cycle and therefore no electrical arc is generated at the DC plug/receptacle contacts.

AC Voltage

Battery charger output is directly related to the input voltage. If multiple vehicles are receiving an incomplete charge in a normally adequate time period, low AC voltage could be the cause and the power company should be consulted.

TROUBLESHOOTING

In general, troubleshooting will be done for two distinct reasons. First, a battery that performs poorly and is outside of the manufacturer's specification should be identified in order to replace it under the terms of the manufacturer's warranty. Different manufacturers have different requirements. Consult the battery manufacturer or a service representative for specific requirements.

The second reason is to determine why a particular vehicle does not perform adequately. Performance problems

may result in a vehicle that runs slowly or in a vehicle that is unable to operate for the time required.

A new battery must **mature** before it will develop its maximum capacity. Maturing may take up to 100 charge/discharge cycles. After the maturing phase, the older a battery gets, the lower the capacity. The only way to determine the capacity of a battery is to perform a load test using a discharge machine following manufacturer's recommendations.

A cost effective way to identify a poorly performing battery is to use a hydrometer to identify a battery in a set with a lower than normal specific gravity. Once the particular cell or cells that are the problem are identified, the suspect battery can be removed and replaced. At this point there is nothing that can be done to salvage the battery; however, the individual battery should be replaced with a good battery of the same brand, type and approximate age.

Hydrometer

A hydrometer (P/N 50900-G1) is used to test the state of charge of a battery cell (Ref Fig. 29 on page 23). This is performed by measuring the density of the electrolyte, which is accomplished by measuring the specific gravity of the electrolyte. The greater the concentration of sulfuric acid, the more dense the electrolyte becomes. The higher the density, the higher the state of charge.

⚠ WARNING ⚠ *To prevent battery explosion that could result in severe personal injury or death, never insert a metal thermometer into a battery. Use a hydrometer with a built in thermometer that is designed for testing batteries.*

Specific gravity is the measurement of a liquid that is compared to a baseline. The baseline is water which is assigned a base number of 1.000. The concentration of sulfuric acid to water in a new golf car battery is 1.280 which means that the electrolyte weighs 1.280 times the weight of the same volume of water. A fully charged battery will test at 1.275 - 1.280 while a discharged battery will read in the 1.140 range.

NOTE *Do not perform a hydrometer test on a battery that has just been watered. The battery must go through at least one charge and discharge cycle in order to permit the water to adequately mix with the electrolyte.*

The temperature of the **electrolyte** is important since the hydrometer reading must be corrected to 80° F (27° C). High quality hydrometers are equipped with an internal

ELECTRIC THREE WHEEL SERVICE VEHICLE

Read all of manual to become thoroughly familiar with this vehicle. Pay particular attention to all Notes, Cautions and Warnings

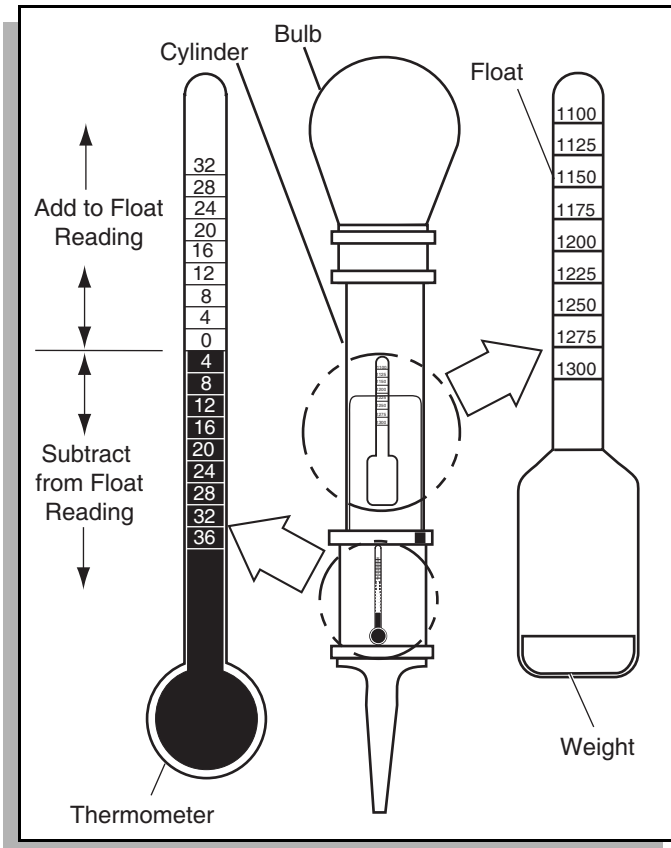

Fig. 29 Hydrometer

thermometer that will measure the temperature of the electrolyte and will include a conversion scale to correct the float reading. It is important to recognize that the electrolyte temperature is significantly different from the ambient temperature if the vehicle has been operated.

Using A Hydrometer

1. Draw electrolyte into the hydrometer several times to permit the thermometer to adjust to the electrolyte temperature and note the reading. Examine the color of the electrolyte. A brown or gray coloration indicates a problem with the battery and is a sign that the battery is nearing the end of its life.
2. Draw the minimum quantity of electrolyte into the hydrometer to permit the float to float freely without contacting the top or bottom of the cylinder.
3. Hold the hydrometer in a vertical position at eye level and note the reading where the electrolyte meets the scale on the float.
4. Add or subtract four points (.004) to the reading for every 10° F (6° C) the electrolyte temperature is above or below 80° F (27° C). Adjust the reading to

conform with the electrolyte temperature, e.g., if the reading indicates a specific gravity of 1.250 and the electrolyte temperature is 90° F (32° C), **add** four points (.004) to the 1.250 which gives a corrected reading of 1.254. Similarly if the temperature was 70° F (21° C), **subtract** four points (.004) from the 1.250 to give a corrected reading of 1.246 (Ref Fig. 30 on page 23).

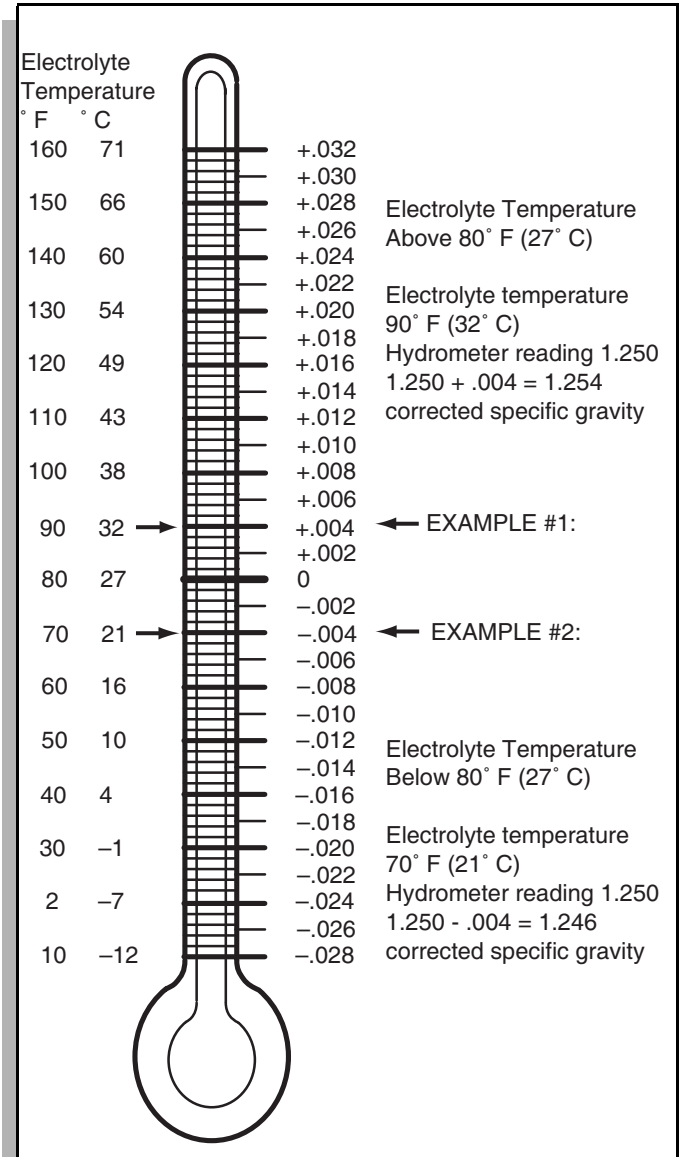

Fig. 30 Hydrometer Temperature Correction

ELECTRIC THREE WHEEL SERVICE VEHICLE

Read all of manual to become thoroughly familiar with this vehicle. Pay particular attention to all Notes, Cautions and Warnings

5. Test each cell and note the readings (corrected to 80° F or 27° C). A variation of fifty points between any two cell readings (example 1.250 - 1.200) indicates a problem with the low reading cell(s).

As a battery ages the specific gravity of the electrolyte will decrease at full charge. This is not a reason to replace the battery, providing all cells are within fifty points of each other.

Since the hydrometer test is in response to a vehicle exhibiting a performance problem, the vehicle should be recharged and the test repeated. If the results indicate a weak cell, the battery or batteries should be removed and replaced with a good battery of the same brand, type and approximate age.

ELECTRIC THREE WHEEL SERVICE VEHICLE

Read all of manual to become thoroughly familiar with this vehicle. Pay particular attention to all Notes, Cautions and Warnings

E-Z-GO FACTORY SET CONTROLLER PARAMETERS					
PARAMATER	RANGE	DEFAULT	DESIRED	UNITS	DESCRIPTION
Current Limit, Main	20 - 250	250	250	Amps	Maximum current forward speed
Current Limit, Low Speed Main	20 - 250	250	250	Amps	Maximum current reverse speed
Current Limit, Plug	20 - 250	70	70	Amps	Max. plug current forward speed
Current Limit, Low Speed Plug	20 - 250	70	70	Amps	Max. plug current reverse speed
Current Limit, Emergency Reverse	20 - 250	140	250	Amps	Max. plug current in emergency reverse
Current Limit, Low Speed Emergency Reverse	20 - 250	140	250	Amps	Max. plug current in low speed emergency reverse
Current Limit, Ramp Start	20 - 250	140	250	Amps	Max. plug current during ramp start
Current Limit, Low Speed Ramp Start	20 - 250	140	250	Amps	Max. plug current during ramp start in low speed
Acceleration Rate	0 - 3	1	0.8	Sec.	Time to reach full output from zero output
Quick Start	0 - 6	1.4	0.2		Output will respond to rate of throttle change
Throttle type	type 1, 2, 3	type 1	type 2	Ohm or Volts	Type of throttle input type 2 = 0-5V, 3-wire pot
Ramp Shape	20 - 70	50	50	%	Adjust desired PWM output at 50% throttle to vary throttle sensitivity at low speed
Creep Speed/Min. Duty Cycle	0 - 25	10	0	%	Speed at min. throttle setting
Low Speed	40 - 100	60	55	%	Max. speed in reverse
High Speed	40 - 100	100	100	%	Max. speed in forward
Emergence Reverse Speed	25 - 100	100	100	%	Speed during emergency reverse
Sequencing Delay	0 - 3	0	0	Sec.	Delays HPD and SRO from brake after controller is enabled
Variable Plug	On/Off	On	On		On = plug current dependent upon throttle position. Off = fixed
High Pedal Disable (HPD)	0 - 2	0	1		Option to disable controller if throttle is applied before brake or keyswitch input (KSI)
Static Return To Off (SRO)	type 0, 1, 2	type brake 1	type 0 No SRO		Sequencing of KSI or brake before direction is selected
Anti - tiedown	On/Off	On	Off		Prevents high speed mode if HSS in not released after brake

Fig. 31 Factory Settings

ELECTRIC THREE WHEEL SERVICE VEHICLE

Read all of manual to become thoroughly familiar with this vehicle. Pay particular attention to all Notes, Cautions and Warnings

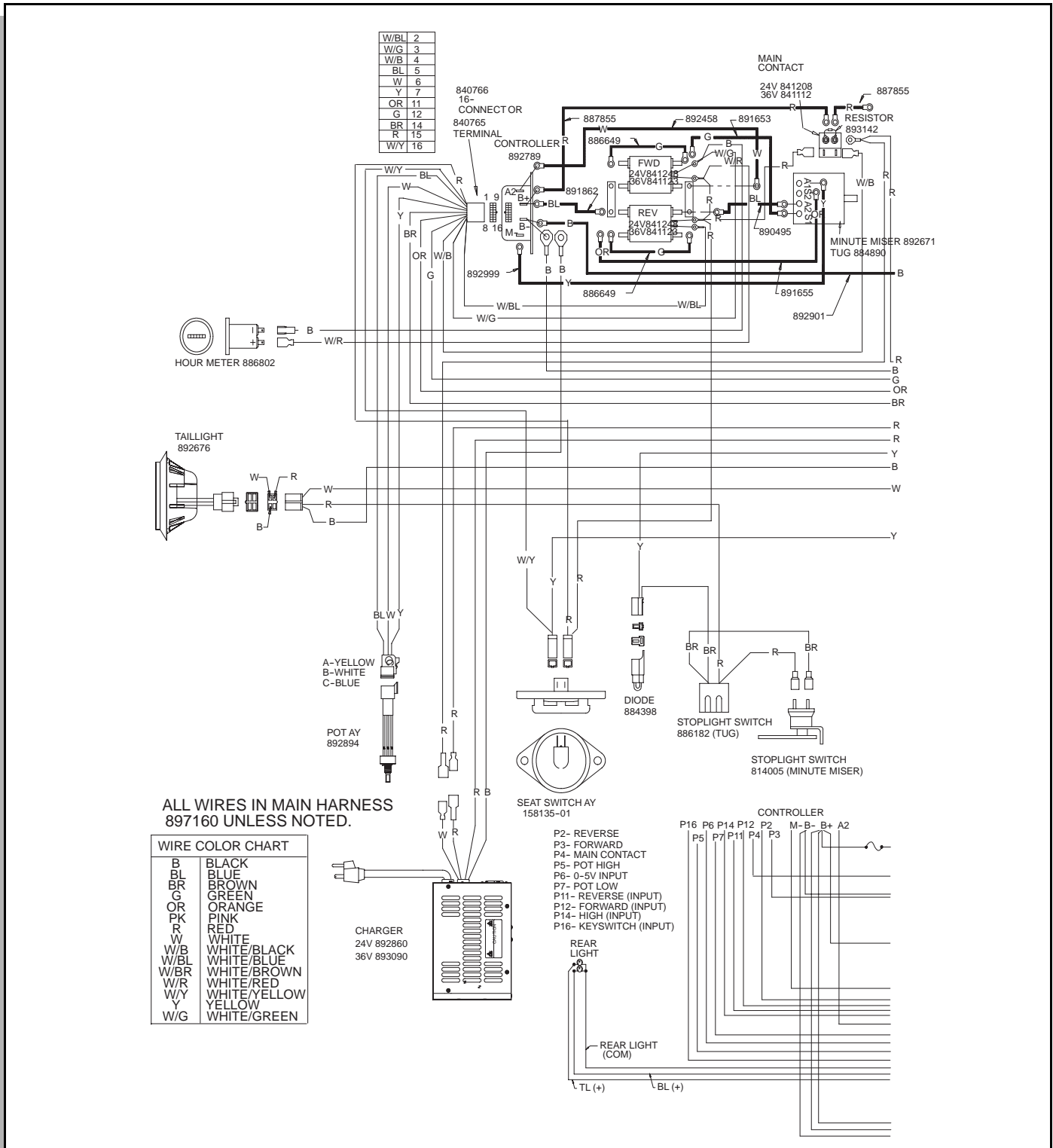

Fig. 32 Wiring Diagram

ELECTRIC THREE WHEEL SERVICE VEHICLE

Read all of manual to become thoroughly familiar with this vehicle. Pay particular attention to all Notes, Cautions and Warnings

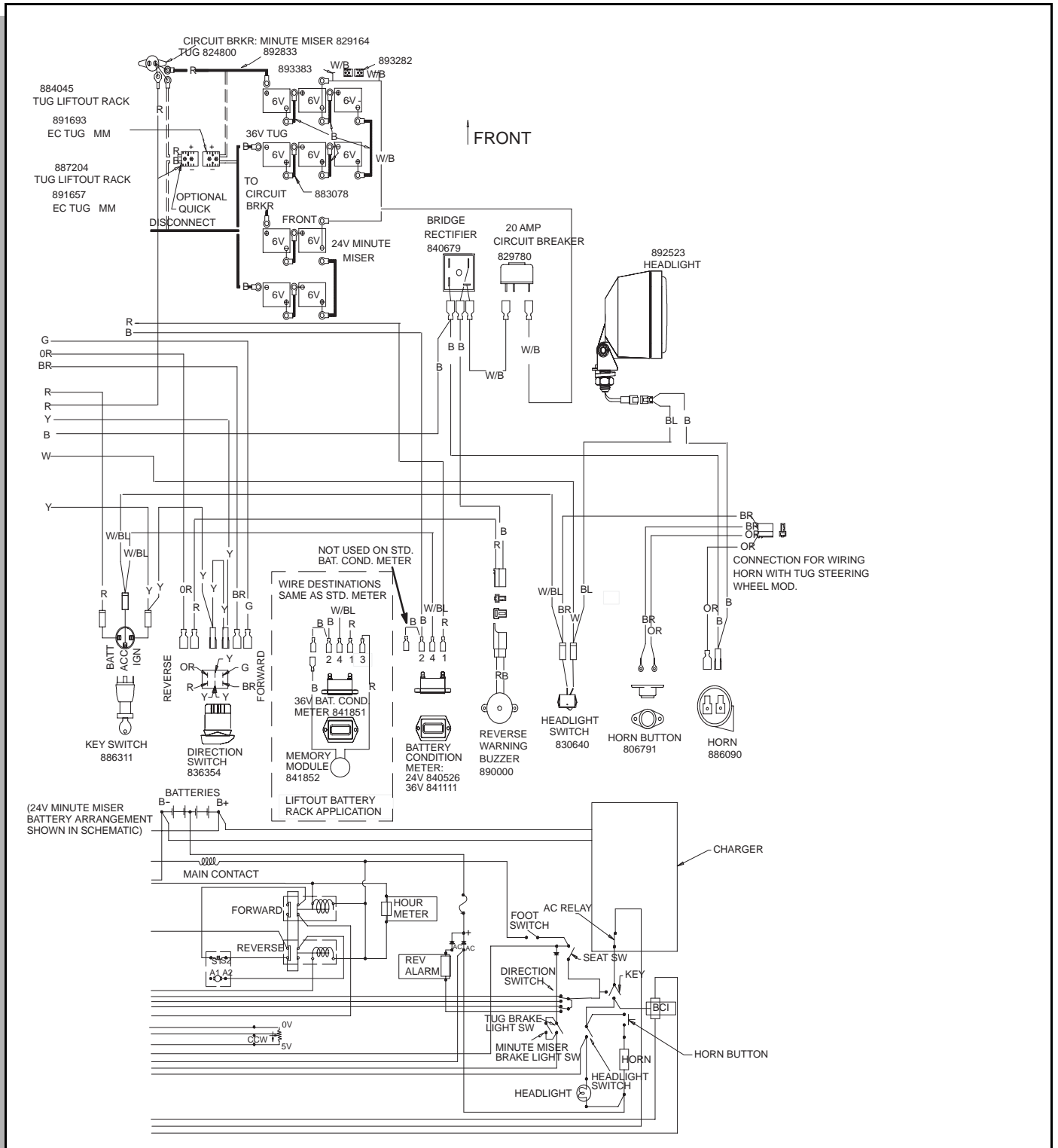

Fig. 33 Wiring Diagram

GENERAL SPECIFICATIONS

GENERAL SPECIFICATIONS

ELECTRIC POWERED THREE WHEEL SERVICE VEHICLE

BATTERY MONITORING	LED State of charge meter
BATTERIES	Four 6 volt deep cycle (105 minute minimum, 225 amp-hour @ 20 hour discharge rate)
SPEED CONTROLLER	Programmable Solid state, 250 amp capacity
MOTOR	24 VDC, series wound 1.5 hp (1.1 kW) @ 2800 rpm & 4.3 hp (3.2 kW) @ 1200 rpm, brazed armature and solid copper windings
REAR AXLE	Bevel gear with spur and helical gearreduction with input pinion shaft directly connected to motor shaft
BRAKES	Dual rear wheel, self adjusting mechanical drum brakes
PARKING BRAKE	Toe lock combined with service brake
FRONT SUSPENSION	Rubber mounted torque arm
REAR SUSPENSION	Coil springs and hydraulic shock absorber
STEERING	Handlebar connected directly to front fork
SEATING	Driver and rear facing passenger
TOTAL LOAD CAPACITY	550 lbs. (250 kg) including operator, accessories & cargo
SPEED	10 1/2 mph (17 kph)
CHASSIS	Welded tubular steel; powder coated (Durashield™)
VEHICLE PROTECTION	None
BODY	Diamond pattern body with Durashield™ Industrial Yellow powder coat paint
STANDARD COLOR	Industrial Yellow
LOAD BED	22 3/4" (58cm) x 28 1/2" (72cms) x 4" (10cms)
LOAD BED FEATURES	Removable panel for powertrain access
LIGHTING (Standard)	Rear brake light
TIRES (Standard)	4.80 x 8 Industrial Load Range B
TIRE PRESSURE	60 psi (415 kPa)
WEIGHT (with batteries)	690 lbs. (315 kg)
OPERATING CONTROLS & INSTRUMENTATION	Removable key, 'deadman' accelerator control, direction selector, audible reverse warning
BATTERY CHARGER	Lestronic II built-in 24 V, 120 VAC, fully automatic, line compensating, 25 amp DC output at 24 volts, 60 Hz, UL recognized, CSA certified
RANGE (Nominal)	35 miles (56kms) max

Specifications subject to change without notice

GENERAL SPECIFICATIONS

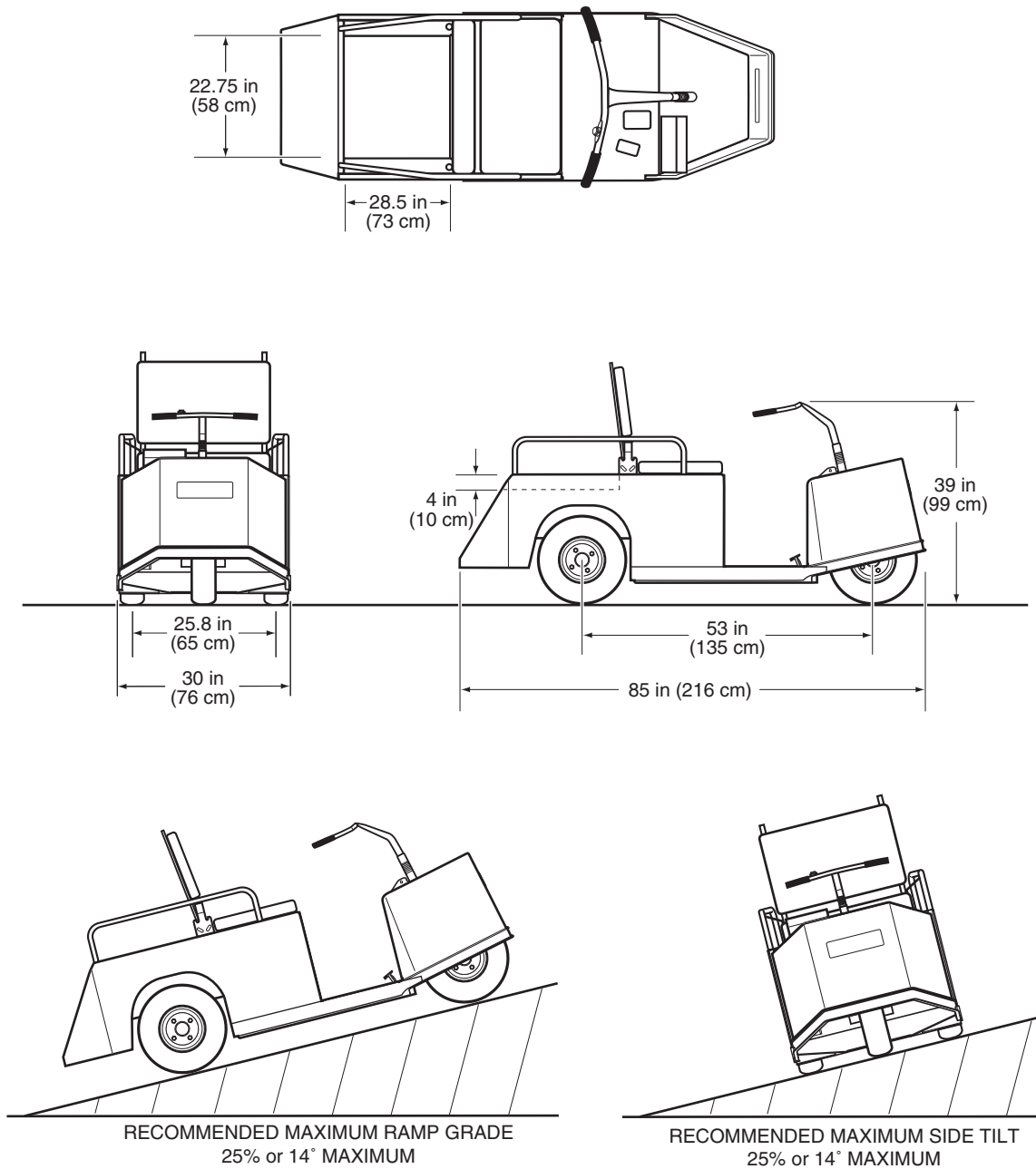

Fig. 33 Vehicle Dimensions and Incline Specifications

GENERAL SPECIFICATIONS

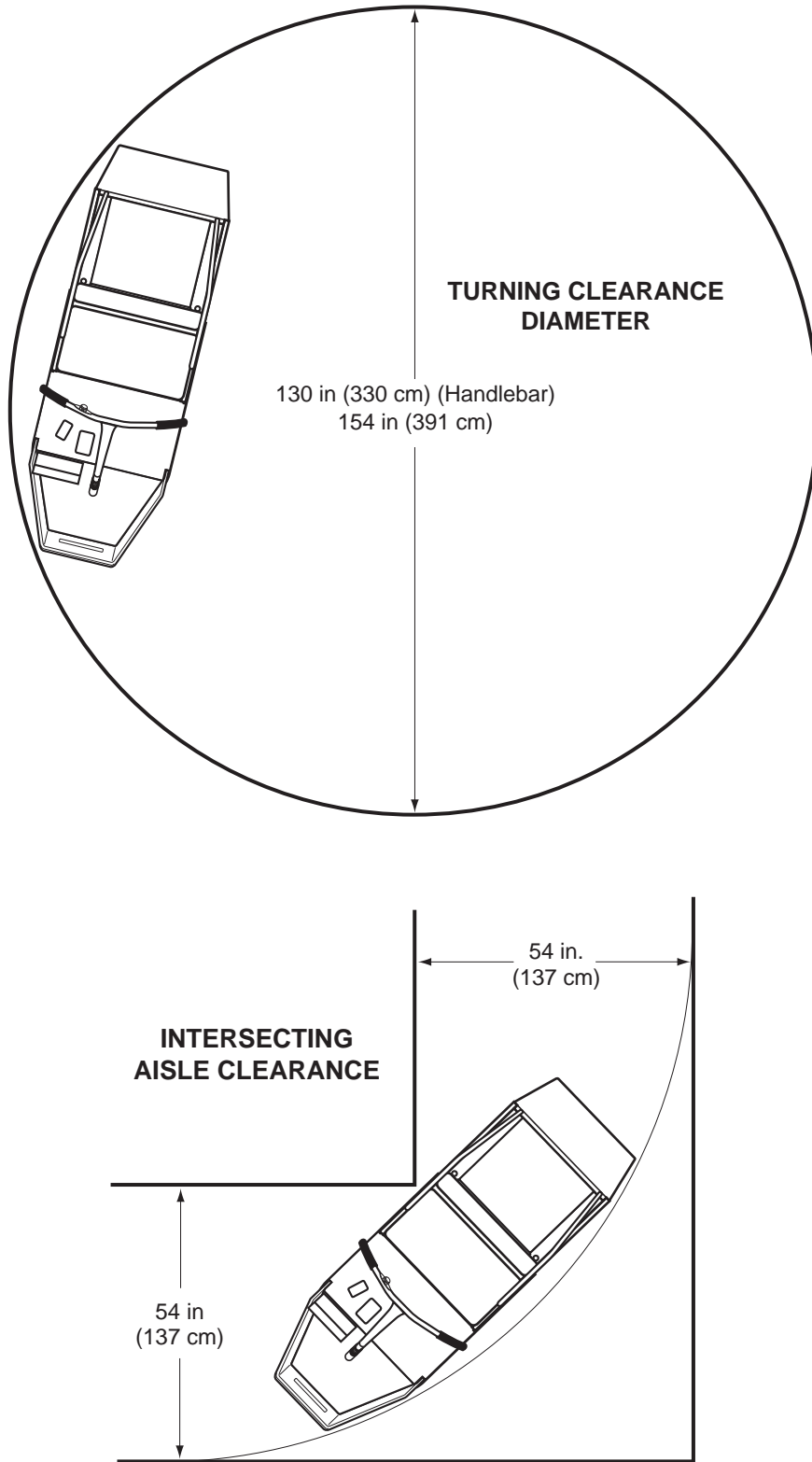

Fig. 34 Vehicle Turning Clearance Diameter and Intersecting Aisle Clearance

NOTE

Read and understand the following warnings before attempting to operate the vehicle:

⚠ WARNING ⚠

To prevent personal injury or death, observe the following:

When vehicle is to be left unattended, release pedal completely, move direction selector to neutral, turn key to 'OFF' position and remove key.

Drive vehicle only as fast as terrain and safety considerations allow. Consider the terrain and traffic conditions. Consider environmental factors which effect the terrain and the ability to control the vehicle.

Avoid driving fast down hill. Sudden stops or change of direction may result in a loss of control. Use service brake to control speed when traveling down an incline.

Use extra care and reduced speed when driving on poor surfaces, such as loose dirt, wet grass, gravel, etc.

All travel should be directly up or down hills.

Use extra care when driving the vehicle across an incline.

Stay in designated areas and avoid steep slopes. Use the parking brake whenever the vehicle is parked.

Keep feet, legs, hands and arms inside vehicle at all times.

Avoid extremely rough terrain.

Check area behind the vehicle before operating in reverse.

Make sure the direction selector is in correct position before attempting to start the vehicle.

Slow down before and during turns. All turns should be executed at reduced speed.

Always bring vehicle to a complete stop before shifting the direction selector.

See GENERAL SPECIFICATIONS for standard vehicle load and occupant capacity.

NOTE

Read and understand the following text and warnings before attempting to service vehicle:

In any product, components will eventually fail to perform properly as the result of normal use, age, wear or abuse. It is virtually impossible to anticipate all possible component failures or the manner in which each component may fail.

Be aware that a vehicle requiring repair indicates that the vehicle is no longer functioning as designed and therefore should be considered potentially hazardous. Use extreme care when working on any vehicle. When diagnosing, removing or replacing any components that are not operating correctly, take time to consider the safety of yourself and others around you should the component move unexpectedly.

Some components are heavy, spring loaded, highly corrosive, explosive or may produce high amperage or reach high temperatures. Battery acid and hydrogen gas could result in serious bodily injury to the technician/mechanic and bystanders if not treated with the utmost caution. Be careful not to place hands, face, feet or body in a location that could expose them to injury should an unforeseen situation occur.

⚠ WARNING ⚠

To prevent personal injury or death, observe the following:

Before working on the vehicle, remove all jewelry (rings, watch, necklaces, etc.).

Be sure no loose clothing or hair can contact moving parts.

Use care not to touch hot objects.

Raise entire vehicle and support on jack stands before attempting to run or adjust powertrain.

Wear eye protection when working on or around the vehicle. In particular, use care when working around batteries, using solvents or compressed air.

Hydrogen gas is formed when charging batteries. Do not charge batteries without adequate ventilation.

Do not permit open flame or anyone to smoke in an area that is being used for charging batteries. A concentration of 4% hydrogen gas or more is explosive.



A Textron Company

E-Z-GO Division Of Textron, Inc.,
1451 Marvin Griffin Road, Augusta, Georgia USA 30906-3852

TO CONTACT US

North America:

Technical Assistance & Warranty Phone: 1-800-774-3946, FAX: 1-800-448-8124
Service Parts Phone: 1-888-GET-EZGO (1-888-438-3946), FAX: 1-800-752-6175

International:

Phone: 010-1-706-798-4311, FAX: 010-1-706-771-4609

Copyrighted Material
This manual may not be reproduced in whole or
in part without the express permission of
E-Z-GO Division of TEXTRON Inc.
Technical Communications Department